

TIMS E-NEWS

The International Molinological Society

Fall/ Winter 2023

Issue 35

In This Issue

[Intro by our President](#)

[World News](#)

[Publications](#)

[E-News Team](#)

Information Links

[Council](#)

[TIMS Home Page](#)

[Membership 2023](#)

[Our Bookshops](#)

[Click here for printable version](#)

INTRO BY OUR PRESIDENT

Dear TIMS Members and Mill Friends,

Without any major TIMS events, 2023 is a quiet year for most of us. However, this is not the case for Jorge Miranda and his team. They are organising the 16th TIMS Symposium in Portugal next year. The symposium will be held at two locations, namely Ponte de Sor (near Lisbon) and Valongo (near Porto), and, in between, there will be a two-day mill tour. It is also planned to have a Pre- and Post-Symposium tour. Registration will start in October. Members will be informed by email and all relevant information will be placed on our website as well. If you are not a member and interested to participate, do check our website.

This E-News is somewhat different. This is due to the fact that the major part of E-News is dedicated to South Africa with an extensive photographic report on the restoration of the Mostert's Mill and a second one on the restoration of a watermill in Franschoek. Both contributions come from Andy Selfe.

Also, this edition lacks a proper Book Corner, as in the past six months no new publications were reported to our E-News editor. There is just one single book review, sent in by Tony Bonson.

Some news from Ukraine. Wiki Loves Monuments is an annual international photographic contest promoting cultural heritage. The goal is to encourage people to upload their pictures of cultural and historic sites to the Wikimedia Commons under a free license, making these photos available as illustrations for Wikipedia, the free encyclopedia daily visited by millions of users. The NGO Wikimedia Ukraine organises these contests in Ukraine. Contests with mills as a theme were held in 2019 and 2020.

Olena Krushynska headed the jury and your President acted as a Jury member.

After these contests we selected 16 photos to be published as a series of postcards. All was ready to be sent to the printer, . . . and then the brutal invasion started.

But Nataliia Tymkiv of the Ukrainian Wiki Loves Monuments team simply refused to give up. And she organised that the postcards got printed, and early this year I received a package with sets of these postcards. The photo below, showing a typical Ukrainian D-15 mill, is shown on one of the cards.



The D-15 windmill in the village of Hryschchyntsi, Kaniv Raion, Cherkasy Oblast, Ukraine. Photo by Oleksandr Malyon.

In This Issue

[Intro by our President](#)

[World News](#)

[Publications](#)

[E-News Team](#)

Information Links

[Council](#)

[TIMS Home Page](#)

[Membership 2023](#)

[Our Bookshops](#)

[Click here for printable version](#)

As always Leo, our E-News editor, would like to encourage you to send us your inputs. So, if you:

- know about a new mill book, please let us know,
- have heard about a mill conference, please do inform us,
- would like to introduce a mill museum or collection, write to us,
- have news you think could be of interest to other mill enthusiasts, let us know!!!

Not a member of TIMS yet? Well, it is easy to enroll, just complete the [on-line application form ...](#)

Enjoy reading E-News !!

Willem van Bergen
[e-mail: wdvb@gmx.de](mailto:wdvb@gmx.de)

WORLD NEWS

USA

Posts from the Tide Mill Institute

The Tide Mill Institute

Posted on March 9, 2023:

Eling Tide Mill back in Operation

[Eling Tide Mill Back in Operation \(mailchi.mp\)](#)

Posted on May 17, 2023:

Tidal Energy News Update, January – April 2023

[Tidal Energy News Update: January – April 2023 \(mailchi.mp\)](#)

Posted on June 4, 2023:

York River Tide Mills Video now available Online

[York River Tide Mills Video Now Available On Line \(mailchi.mp\)](#)

Posted on July 30, 2023:

How Tide Mill Institute promotes modern Tidal Energy

[How Tide Mill Institute Promotes Modern Tidal Energy \(mailchi.mp\)](#)

Posted on August 9, 2023:

Question about Circular Sawmill Blade Construction

[Question About Circular Sawmill Blade Construction \(mailchi.mp\)](#)

Posted on August 16, 2023:

Drama in Tidal Power History?

[Drama in Tidal Power History? \(mailchi.mp\)](#)

Posted on August 29, 2023:

Saw Blade Mystery Resolved

[Saw Blade Mystery Resolved - Tide Mill Institute](#)

Posted on September 16, 2023:

Appreciating Tide Mill Art

[Appreciating Tide Mill Art \(mailchi.mp\)](#)

DENMARK

Dorf Mill Yard

by Anne Provst, Director, and Anders Kilgast Jensen, Curator, Museum of Supply and Sustainability.

Presenting History – How We Communicate the History of Dorf Watermill

Dorf Mill Yard is part of the Museum of Supply and Sustainability, a state approved museum in the northern part of Denmark. When the last member of the family of owners died in 1996 the mill yard became a museum. The history of the mill yard can be traced back to at least 1664, when the watermill was mentioned for the first time. Later, in the 19th century, a windmill and a quadrilateral



yard with stables, barn and farmhouse replaced the one built in 1870 (picture by Zane Reinfeld)

The watermill in Dorf was established to grind grain to flour. From the beginning it was a mill site owned by Dronninglund Castle (former convent of Hundslund), but from 1833 the miller came to own the mill himself. Before the farmhouse was built the whole family lived in the watermill. The rooms were very small, and it was very damp. From 1870 the family moved into the newly built farmhouse, and from then a journeyman miller typically lived there.

Dorf Watermill had an overshot wheel which secured the most efficient use of the water power. In 1922 the owner wanted more flexibility and an even more efficient use of the water power. He removed the old wheel and installed a turbine instead. The turbine drove a generator that produced electricity to the whole farmhouse and part of the stables. At the same time the electricity could be used to run the stones and the hoist in the watermill. The dynamo produced 110 V of direct current. From 1922 until 1997 the watermill supplied the mill yard with electricity – public electricity was installed at some point though, to secure enough power for the television, refrigerator and freezer to work. When the mill yard became a museum the whole yard switched to public electricity, with an alternating current. Two lamps and a hoist in the watermill remained powered by the turbine and generator. In this way the guests at the museum can experience how the water generates power.

New Plans for Communicating the History of Dorf Watermill

The existing information exhibits in Dorf Watermill are scarce, with only a few texts in the residential area of the basement, together with a rather large model of a watermill that is actually of a different mill from the southern part of Denmark. The three basement rooms are otherwise empty, with no furniture or inventory.



After a long period of brainstorming and debating, the Museum has made new plans for the presentation of Dorf Watermill. There are a lot of considerations to take into account when both conservation and functionality concepts have to play together.

A closer look at Dorf Watermill (picture by Thomas Skjold)

In This Issue

[Intro by our President](#)

[World News](#)

[Publications](#)

[E-News Team](#)

Information Links

[Council](#)

[TIMS Home Page](#)

[Membership 2023](#)

[Our Bookshops](#)

[Click here for printable version](#)

In This Issue

[Intro by our President](#)

[World News](#)

[Publications](#)

[E-News Team](#)

Information Links

[Council](#)

[TIMS Home Page](#)

[Membership 2023](#)

[Our Bookshops](#)

[Click here for printable version](#)

As the whole mill yard is a historical, conservation building complex, it limits the possibilities when it comes to new and innovative concepts of communicating its story. The Museum plans on establishing an authentic, living environment throughout the complex, and the same concept will be applied to the residential area of the watermill.

The residential area in the basement consists of one large and two smaller rooms, where the whole family lived before the new farmhouse was built in 1870. Three rooms for parents, children, and sometimes even a few servants. For a visitor in 2023, it is hard to imagine life in these few square meters. Reconstructing the interior of the rooms will help the historical understanding of the living conditions. There will be a kitchen, living room and sleeping alcoves with beds.

We will focus the time around 1850 when decorating the interior, using furniture, glass, etc. that would have been used around that time. Unfortunately, we know very little about the interior decoration of the actual watermill. Therefore, we will research thoroughly about other mills in the nearby area in order to depict it as authentically as possible.

We believe, that by putting the rooms back in time and doing it as realistically as possible, we will be able to create a better and more accurate historical experience and insight into life in a watermill. In the coming years, the Museum will further develop the communication concepts at Dorf Mill Yard, which will include living history and interactive presentations, where historical tools, activities and costumes will be used to bring visitors back in time.

GREECE

Windmills of Skyros

by Marina Aidoni, volunteer at The Mills Archive Trust, Reading, UK
email_greengrass@hotmail.gr

During a short break in the first week of May 2023, I visited the island of Skyros which is part of the Sporades in the Aegean Sea, in Greece. My aim was to find the three windmills I read about in Watlington House and take photos to add to the digital collection of the Archive. The only source of the location of the mills was a book that was written thirty years ago, and the photos of the mills were black and white. I was not certain they would still be there



The first windmill by the sea, converted into a restaurant, SMDN-2023.0025-01

And so, I asked the locals for information on the windmills. On one occasion, I was informed there were a lot of windmills on the island but only four are still standing and just three are in good condition. There were also plenty of watermills, however none of them survive.

Close-up of the same mill, SMDN-2023.0025-03



While at a restaurant, my question about the location of the windmills attracted the staff and owners' attention, and I found myself in the middle of all sorts of lively conversations going on simultaneously. They spoke of the mill owners, their personalities and characteristics, they mentioned myths and awkward stories about the windmills and the millers, and there was gossip and everyone laughed out loud with joy.

In This Issue

[Intro by our President](#)

[World News](#)

[Publications](#)

[E-News Team](#)

Information Links

[Council](#)

[TIMS Home Page](#)

[Membership 2023](#)

[Our Bookshops](#)

[Click here for printable version](#)

As I listened, I could not help but notice that my curiosity and interest in the windmills sparked a great deal of interest and brought people together. I was delighted to see that everyone had something to say, and we all had such a good time! My interaction with the locals and search for the mills was an experience I will not soon forget.



The next day, the search for the windmills began. I was so excited when I saw the windmill that is near Pouria beach! It has been converted into a restaurant that is open during the summer months and it is very popular among the residents and tourists due to its beautiful location. It is built on the edge of a sandy beach and is surrounded by crystal clear water and breathtaking views of the sea and mountains.

The second windmill, being used as a pasta factory, SMDN-2023.0025-11.

The second windmill was very difficult to reach. It is built on a very steep hill not far from the heart of the island, where the schools and shops are located. This mill is not shown on any of the maps of the island so finding it proved to be a challenge. On the way up the rocky hill and while driving a 4x4, for a moment all I could see was the clear blue sky, which was terrifying and yet



Windmill No 3 on top of a hill, SMDN-2023.0025-15

so exciting! A few seconds later, I laid eyes on the mill, it was such a treat! To see the mill with its whitewashed walls and red roof tiles, surrounded by trees and spring wildflowers, made the bumpy ride worth it! To my surprise, I was informed that this mill is being used as a pasta preparation space!

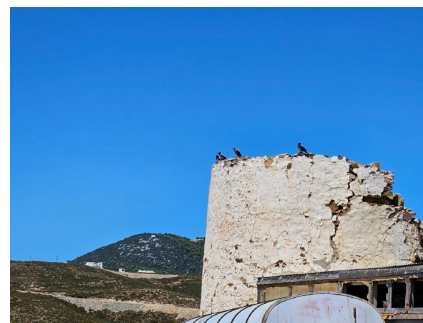

This is another windmill I found on Skyros, in the area of Linaria. It is facing the port of the island and it is well hidden among the residential area. It seems to be abandoned however the local wildlife keeps it company including ravens and goats!

Unfortunately, I was not able to go very close to the third windmill, as it is built on a hill and is surrounded by high walls and trees that do not allow close access. It is one more beautiful mill that has been converted into a home and still stands proud.

Chasing windmills on Skyros encouraged me to talk to the locals, look for information and go to places I would not normally visit. This was the second time I visited the island, and I realised that volunteering for the Mills Archive has helped me look at my surroundings in a different way.

This time, I looked for the details and really saw them. On every journey from now on, I will look for the details and I will chase the windmills!

This article was published as an eNewsletter by the Mills Archive Trust, Reading, UK in August 2023 and is reproduced here with kind permission of the Archive.

UNITED STATES

Locke's Mill Enjoys Bountiful Grinding Season in Virginia

by *Locke's Mill Staff*.

The 2023 grinding season has been a bustling one at historic Locke's Mill near Berryville in Clarke County, Virginia.

This restored Evans-inspired mill on the Shenandoah River re-opened after a winter break on March 18, welcoming a record number of visitors for a day filled with tours, demonstrations, hands-on milling activities for kids, samples of Locke's Mill grits and pancakes, and animals from a local wildlife rescue center as well as the mill's parent company, Ayrshire Farm. We heard reports of guests parking several miles away just to visit, and mill staff found themselves scrambling all day (happily so) to fill roughly \$3,000 in orders of our Certified Organic grains, flours, and baking mixes. Another highlight of the event was the annual bread-tasting lineup, which offered visitors a chance to sample 11 types of single-grain loaves made with the mill's flours, including ancient grains like Einkorn, Emmer, Kamut, and Freekeh. It was exhilarating to meet so many new people, whose interest in the mill ranged from local history and baking to engineering, and, of course, milling.

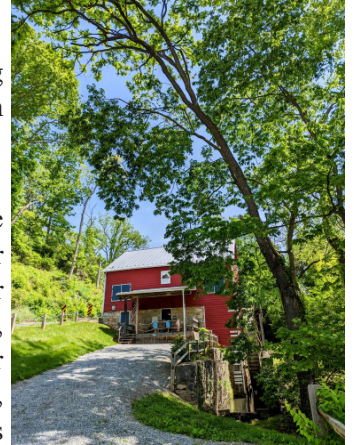

Exterior, seen from downstream



Exterior, showing the huge overshot wheel

Since opening day, the mill has had sensational sales records: We've sold more products so far in 2023 than in all of 2022, not counting online sales. While the numbers are nice, it's even more rewarding to know that others are discovering the benefits of whole-grain baking and fostering a deeper connection with their food. Some of our most popular products this year have been our pre-made mixes. These mixes, which include pancakes (rye, buckwheat, and Swedish), cornbread, spoon bread, and sandwich bread, offer home cooks a convenient entry point to whole grains by simply stirring in a few basic ingredients like water, eggs, or oil. Locke's Mill also produces 14 different types of flour, as well as four varieties of cornmeal and grits (red, white, blue, and yellow) – all of it USDA Certified Organic.

In other news, Locke's Mill has had the pleasure of welcoming a variety of special tour groups and visitors, including school children, a descendant of one of the mill's builders, art classes, and video-drone operators. Also, led by Master Carpenter Billy Holsinger and Ayrshire Farm Manager Chris Damewood, we've been working through the usual fine-tuning and upkeep that are familiar to many a miller. We can't wait to see what the rest of the year has in store.

Grinding in operation



In This Issue

[Intro by our President](#)

[World News](#)

[Publications](#)

[E-News Team](#)

Information Links

[Council](#)

[TIMS Home Page](#)

[Membership 2023](#)

[Our Bookshops](#)

[Click here for printable version](#)

In This Issue

[Intro by our President](#)

[World News](#)

[Publications](#)

[E-News Team](#)

Information Links

[Council](#)

[TIMS Home Page](#)

[Membership 2023](#)

[Our Bookshops](#)

[Click here for printable version](#)



Bagging flour



Several sorts of grits on offer

Locke's Mill is open to the public for tours and sales on the first and third Saturday of each month, March through November, from 11 a.m. to 4 p.m. More information about the mill is available at lockesmillgrains.com and shop.lockesmillgrains.com.

BOOK REVIEW

Millstones of the Pennines and North West England by *David Johnson*.

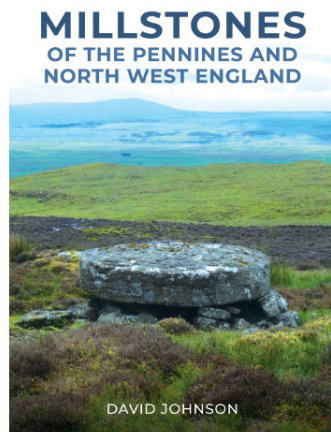

Published by Amberley Books
(www.amberley-books.com), 2023 ,
ISBN 978-1-3981-1293-3.

96 pages, 165 x 234, 180 coloured photographs,
paperback.

Price (UK) £ 14,39 + £ 3 P&P

The book follows on from the author's paper published in the *Archaeological Review*, Vol. 44 , No 2 , November 2022. Research into various aspects of millstones and their manufacture peaked in the 1980s and 90s with a number of papers published and even conferences held solely on the topic, both in the UK and abroad.

This research left millstone making in areas such as the Peak District and Scotland well documented. Between these two areas little was known about millstone making, although the underlying geology is based on millstone grit. The author has scoured this area, finding many examples of "unknown" millstone quarries, enabling him to determine the level and extent of millstone making in this previously undocumented region.

The area of the author's research runs from the Scottish border south to the northern limit of the Liverpool/Manchester/Leeds conurbations, and covers the whole of the western slopes of the Pennine range and the headwaters of the river valleys on the eastern slopes of the Pennines. Within this area the author has identified 56 production sites previously used to quarry millstones.

The process of creating millstones, together with their transportation, are discussed, as are the archaeological remains which consist mainly of unfinished millstones. The documentary evidence for millstone quarrying going back to medieval times is also scrutinised.

In This Issue

[Intro by our President](#)

[World News](#)

[Publications](#)

[E-News Team](#)

Information Links

[Council](#)

[TIMS Home Page](#)

[Membership 2023](#)

[Our Bookshops](#)

[Click here for printable version](#)

The main body of the book is devoted to the descriptions of various millstone quarries including details of the types of unfinished millstones that can be found at each quarry. These descriptions are accompanied by a large number of coloured photographs showing these archaeological remains.

Although some of this information was included in the author's previously published paper, this book has allowed him to expand the coverage of quarries and their remains. The most valuable feature of the book is the inclusion of 180 coloured photographs which ably record the many examples of broken and unfinished millstones to be found across the whole region.

The author highlights the efforts needed, and the conditions endured, by those making this basic component needed to produce the most vital of foodstuffs, namely our daily bread.

There are a couple of niggling inconsistencies caused during the transition from article to published book. However, leaving these aside, the book fills a hole in our knowledge of the history of millstone making in the UK and provides ample visual examples of what to look for when establishing where millstones may once have been produced.

Tony Bonson

YOUTUBE VIDEOS

France

Dr Patrice Cadet of the French Watermill Association shared this video on "Beavers and Watermills: The same Fight" (with automatic subtitling):

[Castors et Moulins : même combat ! - YouTube](#)

Germany

Dutch mill friend Gerard Barendse sent us two German YouTube links:

1. A new life for the Borghorster Mühle in Altengamme near Hamburg:

[Altengammer Mühle - fliegen lernen - YouTube](#)

2. Fitting new sails at the smock mill in the Rhenish Open Air Museum at Kommer (Northrhine-Westphalia) in the traditional way :

[Anbringen der Windmühlenflügel - YouTube](#)

Greece

Katerina Toutouza sent us this YouTube link showing a video on Watermill Hill at Domenikon near Ellassona, Central Greece:

[Ελασσόνα, Δομένικο, Βρυζόστι, Λόφος με νερόμυλους -2023- Ellassona, Domeniko, Vryzosti area, Mill hill - YouTube](#)

Andreas Gkanatsios has a YouTube channel called "Ark of Tradition" that has a large section about molinology and mills in Greece, particularly of the Larisa area (Ellassona county):

[μυλολογία - molinology - YouTube](#)

Serbia

Of the former 282 windmills in Vojvodina, in the Northern part of Serbia, only 11 remain, and none of them is in working condition. An impression of past and present of Melenci Windmill:

[Jedna od poslednjih - vetrenjača u Melencima čeka bolje dane - YouTube](#)

In This Issue

[Intro by our President](#)

[World News](#)

[Publications](#)

[E-News Team](#)

[Information Links](#)
[Council](#)
[TIMS Home Page](#)
[Membership 2023](#)
[Our Bookshops](#)

[Click here for printable version](#)

Slovakia

Ton Meesters sent us several links on Slovakian watermills.

The first is a historic video on boat mills and their successors on the Little Danube:

[Vodné mlyny na juhozápadnom Slovensku - YouTube](#)

Secondly, a historic videos on Jahodná Watermill on the Little Danube:

[Kolový vodný mlyn Jahodná \(1965\) - YouTube](#)

And finally this modern one on Tomášikovo watermill, again on the Little Danube:

[Po stopách vodných mlynov - YouTube](#)

SOUTH AFRICA

Restoring La Cotte Watermill, Franschhoek

by *Andy Selfe*

A visit to La Cotte in the town of Franschhoek in January 2010, ostensibly for a friend to collect seed from a rare Aloe, was the beginning of a patient association with this, then derelict, watermill. The building itself had been restored in 1989, with only the deteriorating waterwheel outside and a burnt-off axle tree on the inside.



In the attic were pieces of another mill; we had no idea where they had come from. On the floor inside, which we could not access, but could see from above, was a pair of

millstones and a lantern pinion on a stone spindle.



The years went by and the place deteriorated further. There was a glimmer of hope in 2018 that the mill might get attention, but it came to nothing. Suddenly in August 2021, there was genuine interest from Mark Dendy Young, manager of this farm/hotel/restaurant/housing complex. What could be done and could I estimate what it might cost to give them a working watermill? By this time we were well into the restoration of Mostert's Windmill in Cape Town, which had burnt in April, and I was getting to know the really best carpenters and they were showing what could be achieved locally. Jon Stevens of Floorscape in Maitland was busy making the cap frame for Mostert's and he seemed to be the best person to approach to do the serious carpentry, while I could concentrate on the milling machinery. We put figures together between us and they were accepted.

In This Issue

[Intro by our President](#)

[World News](#)

[Publications](#)

[E-News Team](#)

Information Links

[Council](#)

[TIMS Home Page](#)

[Membership 2023](#)

[Our Bookshops](#)

[Click here for printable version](#)

The water supply has long since disappeared by 'upstream extraction', so a recirculation system was needed, but that was not part of our brief.

My idea for the axle tree was for Jon to cut back the burnt piece to where there was more or less the full dimensions, then to cut away two opposite quarters beyond that point. He was then to make up the extension out of four quarters, two opposite ones longer than the others so there would be an overlap. He did better than this, by leaving a core at 45 degrees in the middle, thereby increasing the contact area for glueing.

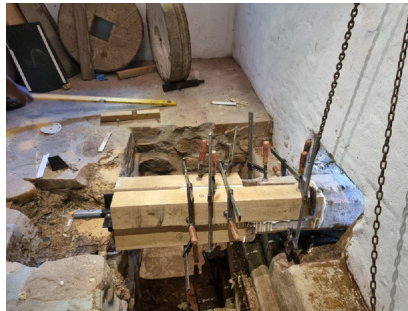

We made two sets of interlocking eye-bolts over the 'splice' and two more over the four bladed gudgeon he set in the end.



He set up his chain-mortiser to make the mortises for the compass arms of the pitwheel we had found in the attic. We have since discovered that those components were brought from Cradock in the Eastern Cape some 800km away, at the time of the restoration of the building in 1989, but never used. After he'd cleaned up the wheel, we found it had five beautiful cants made of Yellowwood! I had granite bearings made and set one into the floor, filling the spaces with pieces of the old original broken mill-stones, which must have fallen in the fire.



Jon then made up new hurstings out of French red oak and set them into the walls at each end.



The lantern pinion and stone spindle had disappeared in the meantime. This led to me having to try and count the rungs from the 13-year-old photo (nine) and to work out a combination of the rung diameter and pitch circle. I made two half-mock-ups before I had the right combination.



I could then make an upper and lower disc and machine rungs with squares at each end, and make nine square holes in the right places of both discs. Not easy, but helped by the purchase of an old Multico mortiser.

In This Issue

[Intro by our President](#)

[World News](#)

[Publications](#)

[E-News Team](#)

Information Links

[Council](#)

[TIMS Home Page](#)

[Membership 2023](#)

[Our Bookshops](#)

[Click here for printable version](#)



I had to make and fit metal bands to prevent the wood splitting outwards. At this point, Mark asked whether it would be possible for the waterwheel to turn even if the stones were stationary. I got around this by making a round stone spindle and boring the discs for two ball-bearings, top and bottom.

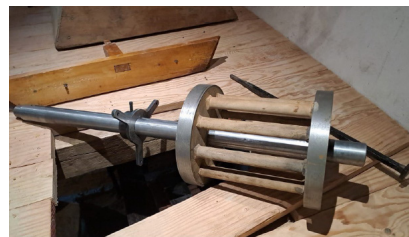

The shaft had a long key-way cut and I made up two keyed drive members with three spokes and holes at the end of each spoke. I drilled corresponding holes in the top and bottom discs and fitted threaded inserts and made up six studs with wing-nuts to transfer the drive.



Jon made the stone floor out of wire-brushed Oregon, we didn't want the hurstings to look 'new'. We opted for a double-ended bridge tree, hinging in the rear uprights and supported by two threaded adjusting stirrups in front. He was able to re-use the main bridge tree which came from Cradock, possibly Ironwood.



able to re-use the main bridge tree which came from Cradock, possibly Ironwood.

I had a bridging box and a bronze footstep bearing made and screwed that to the bridge tree once we had worked out the ideal meshing of the pinion. Then the bedstone could be installed.

The original neck bearing was worm-eaten and the hole was worn out, nor did it match the new stone spindle. I made a new square of wood, forced it in and made up a boring spindle and bored it perpendicular to the grinding face.



A few months elapsed before I got to try out the spindle in the bore, and alerted from a problem on another job, I found the (very well-seasoned) wood had shrunk. The block was loose in the stone and the bore had reduced so the spindle wouldn't go through! I decided to bore it out and insert a phosphor-bronze bush. I honed the hole and bored it with a bar of the same diameter as the spindle, fitted with a fly-cutter. I filmed the process and loaded a you-tube:

<https://www.youtube.com/watch?v=0IN6YEgQPOM>

The bush was made for us, with parallel knurling applied to the outer surface to prevent it turning in the wood. I then glued the block back into the bedstone with Polyurethane glue.

In This Issue

[Intro by our President](#)

[World News](#)

[Publications](#)

[E-News Team](#)

Information Links

[Council](#)

[TIMS Home Page](#)

[Membership 2023](#)

[Our Bookshops](#)

[Click here for printable version](#)



With the footstep bearing fixed down and the bedstone exactly above it and good meshing between the pitwheel and the lantern pinion, Jon cut out a circle in the floor planking so the bedstone now rests on the hurstings. I could then fit the lower part of the curb/tun and we could drill the floor for the dowels which protrude from the underside, to locate it. I opted for a rolled galvanised sheet as a hidden liner to contain the milled flour to be easily swept into the meal spout. There was no spout amongst the old parts, so Jon made one up. The upper round barrel-type tun simply rests on top of the lower section. Mark asked me to install a clear panel in it so visitors can watch the runnerstone turning.



The logo of the establishment is an acorn, because saplings from an oak next to this mill were used to re-plant Delville Wood, where the South African Infantry Division was wiped out in the First World War. I got another member of the Mostert team, Mike Suttan to make adjusting nuts in the form of acorns. Inside are hidden the ends of the threads and ball thrust bearings. They turn easily!

On the outside, Jon stripped off the remains of the shrouds and buckets, extended the rotten ends of the spokes and made up an exact copy of the old one in American white oak. I installed the second four-bladed gudgeon and refitted the original bands, held in place by screws. I cast a concrete plinth and set the other granite bearing in it. A wooden box keeps dirt out of the grease on the spindle.



Working from old photographs dating from 'before 1906', Jon made and erected a new wooden launder, I made a control flap and we installed a lever through the slot next to the frame of the miller's window. This now works with a rope and pulleys inside.



We didn't find any form of horse among the parts in the attic. There were just two uprights on top of the tun, so we had to guess what it might have looked like. Also there was no twist peg, so I made one up and, using hints from James Walton's book on local mills, fitted it to the front of one of the original uprights. I also made a damsel copied from one of his drawings.



In This Issue

[Intro by our President](#)

[World News](#)

[Publications](#)

[E-News Team](#)

Information Links

[Council](#)

[TIMS Home Page](#)

[Membership 2023](#)

[Our Bookshops](#)

[Click here for printable version](#)



We are displaying the burnt-off inner end of the axle tree and some of the parts left over from the Cradock Mill, and now we're waiting for the water system. It has been an extremely interesting project, joining up parts of two different derelict mills, to give one life again! We thank the owners for their vision.

The Sails Are Up!

by Andy Selfe

Part 11

March 2023

Hello all,

Well, the windshaft and sails are in! There has been unbelievable feedback, appreciative comments, 'likes', 'loves', 'wows'.

Well, the sails are up at Mostert's Mill! Much planning had gone into today, not least the wind factor. It looked as if tomorrow, Thursday would be less windy, but Johannes Uys of MME, in charge of the rigging and craning, was confident, particularly as the wind was coming from directly behind the mill.

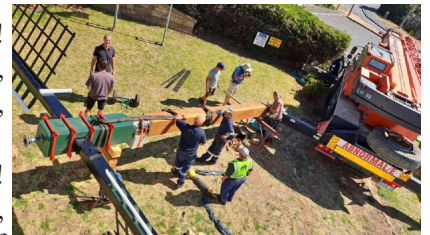

As it happened the wind did abate at the critical time, although I did battle to keep the bare second stock square in the mortise as it was lowered in! Johannes had calculated that water in a flow-bin hung from the front of the poll end, plus the fully assembled outer sail in its mortise closest to the end, as suggested by Paul Moonie Kemp, would balance the assembly, if slung just outside of the overhang of the thatch roof.

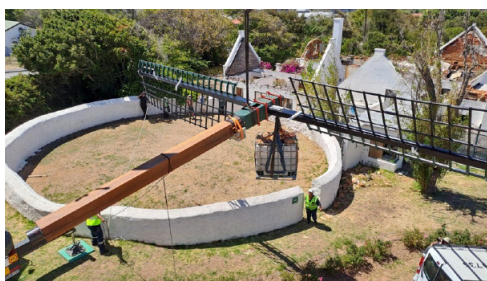

The water was running in slowly from a domestic garden tap, so we added three chain-blocks and any heavy rocks we could find.

Eventually it was possible to lift the tail bearing with a finger, and we were ready to lift, swing away from the tower to an open space over the threshing floor, turn it 180 degrees, then feed it carefully into the opening at the front. Then we discovered we'd mis-calculated the height of the pillow-block that the stone bearing rests on. It was too high!

In This Issue

[Intro by our President](#)

[World News](#)

[Publications](#)

[E-News Team](#)

Information Links

[Council](#)

[TIMS Home Page](#)

[Membership 2023](#)

[Our Bookshops](#)

[Click here for printable version](#)

We compromised and laid the block temporarily on its side and lowered the stone bearing, already strapped to the windshaft, into place. The crane could then lift the other sail stock at the end already assembled with lattice-work for the sail, and the bare half could be lowered through the other mortise and wedged when it came to rest on the stock shoulder block.

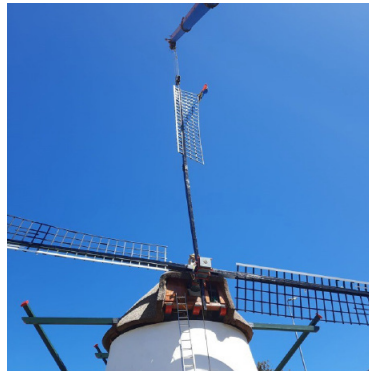

Pilot John then rushed home to collect the decoration for the end of the windshaft so I could install it. Straight Jon can now assemble the fourth set of lattices!

The third lift of the crane was the brake pole, much easier to lift with a crane with its long outer section and operating chain! So Jamie the Scottie's mate is 7m in the air!



We drilled a hole for the anchor chain in the end of the tailpole, primed it and then drove in a 40mm PVC tube so the chain won't wear the soft spruce.

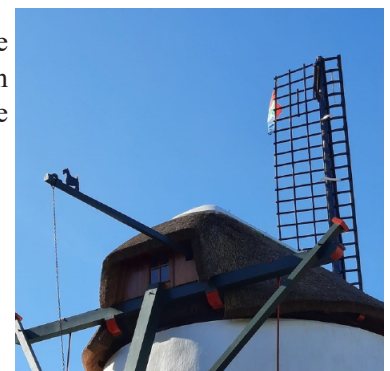

Last thing, we strapped the sails back against the long stretcher in case of being tail-winded, as we can't 'Wind the Cap' into the prevailing wind from the south, until the fourth sail is assembled. The assembled end will swing to the bottom if the two guy ropes at the ends of the now horizontal sails are released!

I asked a well-known local photographer, Irene McCullagh, to record the proceedings in stills, Keith Wetmore as usual will do a follow-up video. Irene put together this selection of stills she took and put it on a you-tube:

<https://www.youtube.com/watch?v=N0zubvGLkzs>

At the same time, in the Netherlands, our team was putting the final touches to the pair of millstones which they have bought with the proceeds of the crowd funding:

In This Issue

[Intro by our President](#)

[World News](#)

[Publications](#)

[E-News Team](#)

Information Links

[Council](#)

[TIMS Home Page](#)

[Membership 2023](#)

[Our Bookshops](#)

[Click here for printable version](#)



This team will be visiting us shortly to check up on our progress! Also beavering away, Charel and Juan are making great progress with the 'furniture'. Here is the curb which will hold the bedstone in place, made from reclaimed wood from a house on a farm here in Elgin:



Detail of the corners. NO nails or screws, dowels they have made with the same wood!

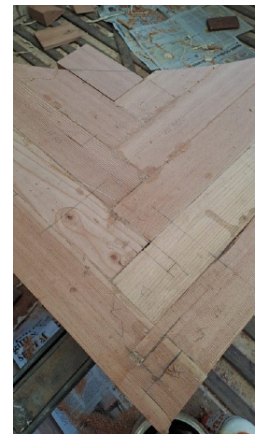

Here are the rings for the top and bottom of the tun:



Since Wednesday, the internal scaffolding has been removed and a mobile tower erected so Kimon can continue with the beams and floors. Full steam ahead!

Part 12 Harps and Sickles

March 2023

Hello,

I have read your article on stone dressing in Leo's E-News, and thought I'd add a snippet. As you will see further on in the newsletter, I'm involved at Mostert's Mill in Cape Town, at the moment re-equipping it after a devastating fire. However, I had been involved in several upgrades in the years before the fire, the last being the re-lining of the brakewheel and re-sizing the brake blocks to suit, which we finished the afternoon before the fire!

One of the upgrades was in connection with the millstones. The mill was restored in 1995 mechanically with a new brakewheel, we think windshaft and other upgrades, but the millwrights didn't fine-tune the actual milling process. Even the bedstone wasn't level! We think they didn't expect actual milling to take place and that the mill would just run for show. In fact milling has taken place about monthly ever since!

To the dressing: At some stage the bedstone must have been replaced with one of a different material and with sickle dressing, where the runner had harps. This was not an ideal combination and when we had the stones open, first to level the bedstone, then to balance, at least statically, the runner we made a snap decision to cut harps over the sickles on the bedstone. We made a template of the dressing off the upturned runner and replicated that on the bedstone.

In This Issue

[Intro by our President](#)

[World News](#)

[Publications](#)

[E-News Team](#)

Information Links

[Council](#)

[TIMS Home Page](#)

[Membership 2023](#)

[Our Bookshops](#)

[Click here for printable version](#)

Here the runner is hanging on a dummy cock-head with the cable attached dead centre. We had to add 20kg of lead to the top to make it balance!



The (well-worn!) sickles.



Making the template off the runner.



Cutting the almost upright edges of the furrows, through the template.

One harp cut, vertical edge only.



Then the angled grinding sloping sides.



Here you can see we are closing the now balancing runner over the bedstone with both styles of dressing.

We had no cause to open the stones again and in the fire they fell from the stone floor and the bedstone was badly broken, the runner is cracked, so we're settling for a pair of second-hand French Burrs which worked at a watermill in Barcelona. They are harp-dressed and our supporters in the Netherlands are making sure that by the time they arrive here all we have to do is to install them!



In This Issue

[Intro by our President](#)

[World News](#)

[Publications](#)

[E-News Team](#)

Information Links

[Council](#)

[TIMS Home Page](#)

[Membership 2023](#)

[Our Bookshops](#)

[Click here for printable version](#)



Incidentally, this is how they looked after we rolled them out of the ashes, the bedstone on the right showing the harps prominently.

We plan to set them into the floor of the Mill.

Part 13 Sails: The Finishing Touch!

May 2023

Busy day at Mostert's Mill today! A very early start from here to avoid the worst of the traffic, I started off by 'saw-gauging' between the lower ends of the long braces where the angles I calculated weren't quite right, where they join the tailpole.

I had cut a piece of poly-propylene (like perspex) and attached it to one side of the saw with thin double-sided tape to hold the blade a certain distance away from the tailpole and to avoid damaging it.



The stud is still in place, so I had to saw from all sides, to work all around the stud. That job isn't finished yet, and we'll need to get primer on the exposed end-grain of the wood before we pull it all together.

The big job was to get the new correct 'pillow-block' under the neck bearing, which meant jacking up the windshaft and somehow the stone bearing with it. Jon had brought the new one with the 2-degree taper built in, as well as an indentation on the underside for the top of the stud that goes through the burgemeester below it. We used my 12-tonne jack standing on the burgemeester.

To add extra weight to the tail of the windshaft, I decided to attach the brakewheel to it with the wedges that had been made. It's not necessarily in the right place yet, to mesh with the lantern pinion, but at least it's a start! The windshaft



In This Issue

[Intro by our President](#)

[World News](#)

[Publications](#)

[E-News Team](#)

Information Links

[Council](#)

[TIMS Home Page](#)

[Membership 2023](#)

[Our Bookshops](#)

[Click here for printable version](#)

landed up slightly smaller than planned, so the wedges go in a bit too far. We might have to make more, or add thickness to these.

At least it meant we could turn the sails later! Theo and Khaya managed to strap the neck bearing to the windshaft, so they came up together, and by climbing the sail, I was able to knock the temporary one out with a mallet.

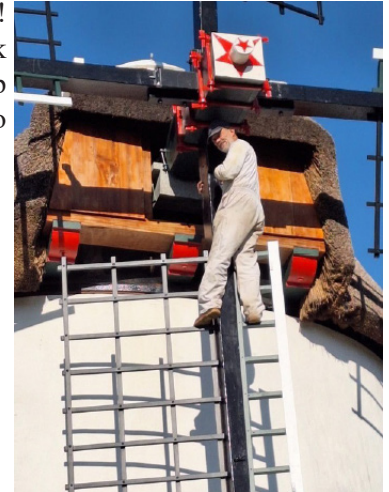

The view from up there is magnificent, but not so much looking down on De Meule, still untouched.



The new pillow block had to have slots cut in it for the 'folding wedges' which are knocked in from both sides and exert a parallel force. We were then able to centralise the neck bearing and lower it on the pillow block, and wedge the neck bearing from both sides. We could then turn the sails! But only a quarter-turn to start with because the side wedges weren't in the mortise of the sail that was vertical, and it could have moved! Once that sail stock was

horizontal I could knock wedges in, and also mark the position for the holes to be drilled in the remaining retaining block (keerklos, in Dutch).

Jon and his team could then wedge the tail bearing the 2 degrees difference where we had to lower the angle of the windshaft by that much. We did some experimental turning of the sails, and were able to leave them in the 'St Andrew's Cross' position for the first time.



Now Mostert looks, from the outside, like in all the picture post-cards!

This weekend is International Mills Weekend, we hope to put up some bunting, if we can find it!

Part 14 Starting on the Inside

Early July 2023

Hello all,

Since the last update at the beginning of May, it might look from the outside as if nothing is being done. Far from true! The focus has naturally been inside, with Kimon Mamacos making and fitting the heavy floor beams for first, the dust floor and, as scaffolding could then be dismantled, the even heavier stone floor beams which measure 280mm (1 foot) square. Rather than making half-laps where they cross, which make both beams weaker, he used his Japanese CNC dovetailer.



In This Issue

[Intro by our President](#)

[World News](#)

[Publications](#)

[E-News Team](#)



The other ends, he prepared for the original tee-shaped brackets which were cut out of the wall (they went right through) and galvanised again. The stone floor beams were too big for the machine, so he made templates for his Mafell router and made double dovetails. From underneath, nobody will be able to see they're not lap-jointed; from above they will be covered by floorboards anyway!



All the time the vertical shaft had to be positioned within the square made by the crossing beams. As soon as the beams were in position, they were fixed into the walls and lime plaster applied up to this level, leaving a wide step for the floor planks to rest on all around, on both levels. On the machinery side, we now

had a height from the stone floor beams to the meal floor, and I could continue with the hursting pillars. I lap-jointed the top ends to be snug up against them and the floor planks above.

Then again working off the Zamani Project 3D scan, cut out the slots for the bridge tree to pass through, and drilled holes to attach these to the stone floor beams. With well over a century old Burmese teak reclaimed from a partly-burnt house, you can be sure I was being careful with measurements!



We dropped a plumb line from the pintle bearing and made some measurements and marks on the stone floor beams, and assembled the first pillar, then drilled right through the beams and fixed that one.



The second one followed, although, having drilled the holes, we couldn't bolt it tight, because the bridge tree had to be fed in!

Information Links

[Council](#)

[TIMS Home Page](#)

[Membership 2023](#)

[Our Bookshops](#)

[Click here for printable version](#)

In This Issue

[Intro by our President](#)

[World News](#)

[Publications](#)

[E-News Team](#)

Information Links

[Council](#)

[TIMS Home Page](#)

[Membership 2023](#)

[Our Bookshops](#)

[Click here for printable version](#)



We could also use the plumb line to work out the final position of the brake wheel. The wedges were too thin, because of the taper on the windshaft, so I added a *Eucalyptus paniculata* layer to each.



We're happy with the result and the run-out both radially and 'wobble' are within acceptable limits.



Once the second hursting pillar was up, we could make final measurements for the bridge tree itself. I had prepared one end, but the 'tongue' at the 'working end' wasn't long enough for the lighter-bar to pass the stone floor beam and floor, so that had to be lengthened. This is a piece of, we think *Baikiaea plurijuga*, known as African teak, Mukusi, Rhodesian teak, Zambian teak or Zambesi redwood. It certainly is much redder than the Burmese!

The tongue at the other end could then be prepared, after cutting off the excess.

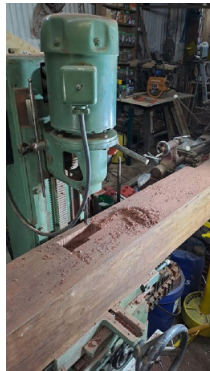

From the plumb line we also found the exact position for the footstep bearing, a cast-iron square with a recess for a dome washer. I deliberately made the socket slightly bigger than the square, to allow for adjustment and wedging/spacing during trammeling. I started with a chisel and quickly gave up and did the job on the Multico mortiser!



It could only do half this way around, so I had to turn the whole (heavy) lump around and work from the middle outwards! Naturally the base of the socket was rough, my router couldn't reach the bottom so I used an attachment I'd made for the die-grinder to clean it up.

We took it through the next work day and after a bit of planing to correct slight out-of-alignment, we rigged it in. Although stiff, with the weight of the runner stone and vertical shaft, there won't be any problem, the advantage being no wobble either!



It was a relief to see the plumb bob dead centre in the socket for the footstep!

In This Issue

[Intro by our President](#)

[World News](#)

[Publications](#)

[E-News Team](#)

Information Links

[Council](#)

[TIMS Home Page](#)

[Membership 2023](#)

[Our Bookshops](#)

[Click here for printable version](#)

We had to get the vertical shaft out of the way for the flooring. It was always too long, being the partly-burnt old tailpole. Now we were getting closer to knowing how long it must be, and although at this stage with a safe margin, we cut a piece off the top end.

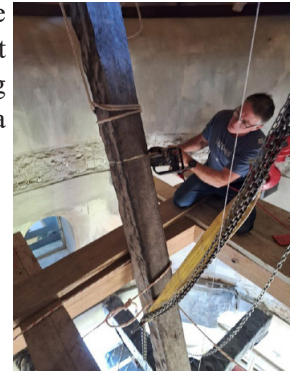

I could then start on the tentering mechanism; there's first a 2:1 lever with the lighter bar attached in the middle, the free end of that is attached to the lighter staff. I was thinking of using the 5th Burmese teak pillar for that, but there were old mortises through it, just short of our ideal length. I had a piece of Oregon pine from an old railway cottage near here that was being dismantled, brick-by-brick. The railway came through here in 1901. Nice job for a shooting plane!

One end had to be rounded for a rope to pass over it from the meal floor below, and I turned a cap for the end out of what we think might be *Entandrophragma cylindricum*, a tree of the genus *Entandrophragma* of the family Meliaceae. It is commonly known as sapele or sapelli or sapele mahogany. I attached the hook at the other end which engages the end of the 2:1 lever.



As soon as we had the hursting pillars in the builders, Bruce Dundas could start on the meal floor. They had to break out and remove two large lumps of concrete which were part of the 1995 restoration. The original pillars had rotted off and they cut them off and added pieces of wood set on concrete blocks.



To avoid this in the long-term future, I've set galvanised forks in the interface of the two halves of the pillars, so the wood will end exactly on floor level. We decided to set the old cracked millstones in the floor.

Concrete is best left for a week, the blue slate will be set in around them as the floor was before. Next jobs: floor planks and trap doors in the dust floor. Lime plaster from the floor upwards to complete the band left previously. Start assembling the brake mechanism, now that the brake wheel is in position. Bring in the 'new' millstones! Complete the 'furniture'.

Keith has just completed three more videos:

Thatching: <https://www.youtube.com/watch?v=18yivAjlVLI>

Installation of the braces: <https://www.youtube.com/watch?v=5AsKJqtTBxc>

and the installation of the windshaft and sails: <https://www.youtube.com/watch?v=GJIT9pQrUeI>

Part 15 The Stones and Brake Assembly Mid July 2023

Hello all,

More progress to report at Mostert's Mill!

In the second-hand bedstone which, with matching runner, came from The Netherlands (having worked in a watermill in Barcelona), was a cast-iron adjustable neck-bearing. It was loose in the stone, so we took it out.



I took it home and made a set of 'jaws' for it with a taper-on-a-taper.



They had to be radiused to match the stone spindle, so I set up a fly-cutter in the lathe, set to the 2 1/2" diameter.

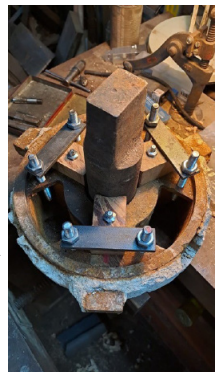

I made up bridge plates with studs to adjust them, and drilled passageways to be able to apply grease in the middle of the jaw.



On Wednesday, again with the assistance of Jakes, we un-crated the stones and lifted the runner off.

We rolled it away to rest against the tower.

The markings.

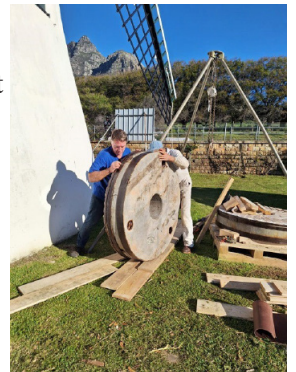

We then realised that in our situation, the neck bearing needs to be the other way up, to be able to adjust the play and apply grease from underneath, so there will be some chiselling needed to get it to the right depth.

In This Issue

[Intro by our President](#)

[World News](#)

[Publications](#)

[E-News Team](#)

Information Links

[Council](#)

[TIMS Home Page](#)

[Membership 2023](#)

[Our Bookshops](#)

[Click here for printable version](#)

In This Issue

[Intro by our President](#)

[World News](#)

[Publications](#)

[E-News Team](#)

Information Links

[Council](#)

[TIMS Home Page](#)

[Membership 2023](#)

[Our Bookshops](#)

[Click here for printable version](#)



We then changed our attention to the brake assembly. The lower brake has been under my feet in the workshop for more than a year!



We roped it up into the cap (we're still waiting for the floors to be installed!).

Pilot John tied it against the brake wheel.



With reference to photos from before the fire, we could see the two anchor eye-pegs were diagonal through the right hand shear.



So (with some hiccups, like the auger coming loose from the extension and a spade-bit braking off in the hole!) we drilled and reamed two holes and installed the pegs.

..... and connected up the swinging link.

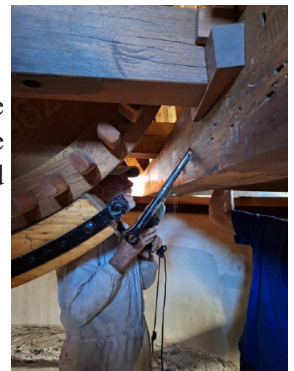

The upper section is ready to rig into position and to have the right-hand end cut off to length.



Then we can connect up the sword iron, still here in the workshop.



News from today is that the extended entrance gate has been installed. It looks great! Now for the rest of the fence along the highway and down towards Welgelegen!



One of my other jobs, the new-build watermill for Soetmelksvlei, got significantly further today, as can be seen on this 'tube': <https://youtu.be/2PcNxQc3YBI> Satisfactory steps!

Part 16 More on the Brake Assembly

End of July 2023

Busy day at Mostert's Mill again today! Our aim was to get as far as possible assembling the brake, a band of heavy, thick poplar blocks I made more than a year ago. The main, upper section was lifted into the cap by the crane in June last year.

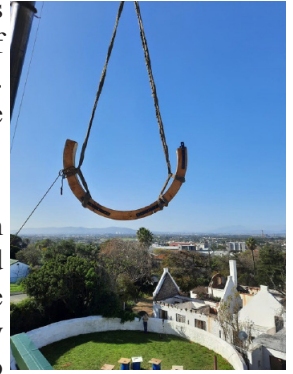

We man-handled the lower section into position last work-day and drilled holes for the anchors in the right hand shear, but I wasn't happy with the alignment and angle, so today we plugged those holes by glueing dowels in them.

I had found a photo which showed the top ends at the upper outer corner of the shear.

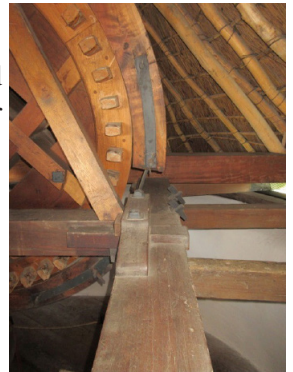

I've recently made an adjustable drilling guide, modelled on a hand-operated, two-handed drilling machine, as used by carpenters of yore.

I bought a long auger and had a sleeve made for the guide to match that auger.

We set the angle at 45 degrees, then measured across and then down. Looking at old photos we could see that would have brought the anchors out too low, so we settled for 42 degrees. The two holes came out nicely in line with one another, also in line with the pull on the lower brake!



We could then work out where to cut off the end of the upper brake assembly, which I deliberately made too long at the time.

We could then sling it into place over the brake wheel.

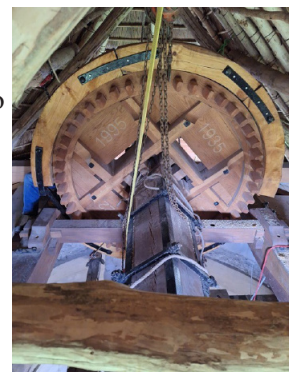

In This Issue

[Intro by our President](#)

[World News](#)

[Publications](#)

[E-News Team](#)

Information Links

[Council](#)

[TIMS Home Page](#)

[Membership 2023](#)

[Our Bookshops](#)

[Click here for printable version](#)

In This Issue

[Intro by our President](#)

[World News](#)

[Publications](#)

[E-News Team](#)

Information Links

[Council](#)

[TIMS Home Page](#)

[Membership 2023](#)

[Our Bookshops](#)

[Click here for printable version](#)

We could then connect the top to the lower brake on the left hand side.

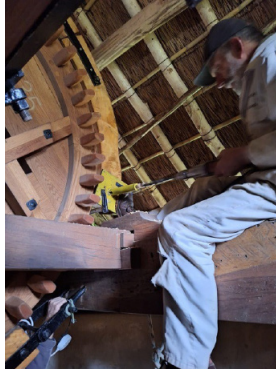

Then we could drill and fit the bracing plates for the sword iron which pulls the brake on, on the right. I was using 'Abie' the perpendicular drilling guide for the upper and lower holes in the braces. I was very pleased that the upper hole came out dead in line with the hole in the brace on the other side!

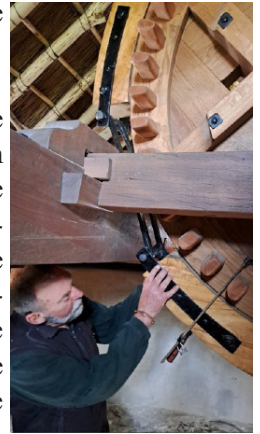

Next was to make a slot in the end for the upper end of the sword iron. We didn't finish that, but we did man-handle the brake lever up into the cap, in preparation for fixing the 'Esel/Ezel' which it pivots on, under the sheer. We now have to make up a 'rest' for the lower end of the left hand side of the upper brake, so when it's released, the weight of the lower brake doesn't pull the upper brake down and drag on the top of the brake wheel.

Good progress!

Part 17 Finetuning the Brake Assembly

Early September 2023

Hello all,

These last few weeks, we've been concentrating on finishing the brake. We're nearly there! As we left it yesterday, the brake pole which sticks far out of the back of the Cap was in the classic 'BRAKE ON' position, for the first time since the fire.

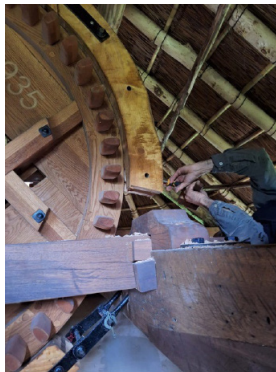

In the last update we were drilling the right hand end of the upper brake assembly for the sword iron which pulls the brake on. The notch wasn't quite deep enough, so last Saturday some chiselling was needed.

Then with the pin inserted in the top of the sword iron, Jakes could bend it to clear the sheer and then face vertically down.



All the wooden parts have been made, working from dimensions from the 3D scan, mostly using reclaimed wood after the fire, for about a year, so we could just start assembling. Once the sword iron was passed through the slot in the brake lever, we could work out where to fit the 'Ezel' from which it hinges, then drill a hole in the sheer above and fit the stud.

In This Issue

[Intro by our President](#)

[World News](#)

[Publications](#)

[E-News Team](#)

Information Links

[Council](#)

[TIMS Home Page](#)

[Membership 2023](#)

[Our Bookshops](#)

[Click here for printable version](#)

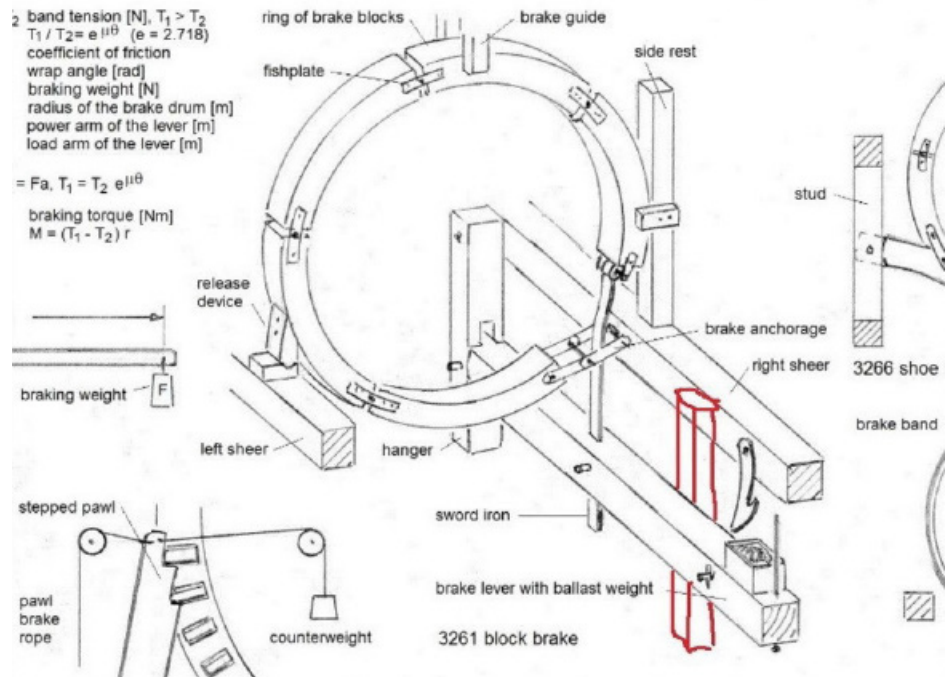

The 'Ezel' (hanger in English) is a piece of Jarrah, the brake lever is Sapele, the shear is Ekki or Bilinga and the stretcher above left is Spruce. The brake wheel on the right is American White Oak with Beech cogs. The roof trusses are Poplar and the mallet is Grey Ironbark! We tried to fit the vertical member which guides the rear of the brake lever and has the 'OFF' hook attached, but the auger blunted on whichever wood that is in the rear part of the shear, Ekki or Bilinga, so we gave up! I can't find a name for this vertical member in the TIMS illustrated Dictionary.

[Note: A few days later Andy reported: I have two identical answers in Dutch for the part which I have sketched in here, not shown in the (excellent!) drawings in the TIMS dictionary: From our regular advisor Sven Verbeek: hangereel in Dutch, or short: just 'hanger'; the other, on my FB query, Johan Vanderstelt gave "hangereel". The 'hanger' shown in the drawing at the front of the Brake-lever in Dutch is 'ezel', a familiar name for us. Esel is a donkey in Afrikaans.]

When the brake is 'OFF', the left hand end of the upper brake assembly furthest from the sword iron must rest on a crutch, otherwise it will hang on the brake wheel and cause drag, heat and possibly fire. I see in the drawing 3261 above it's called a 'release device'. There was a suitable piece of Jarrah in the reclaimed scraps, so we sanded a vertical flat on the outer end of the brake block and after a bit of deliberation, rounded the lower end and attached it.

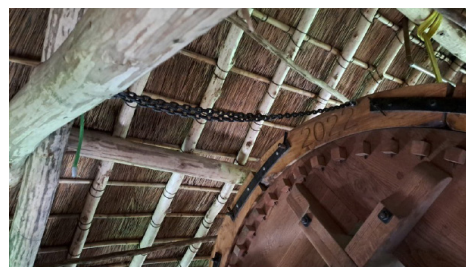

I marked off another scrap of Sapele with the same curve and took it home. We could then screw eye-bolts into the top and bottom brake blocks and into roof members and the underside of the burgemeester and attach the light chains which hold the brake centrally over the brake wheel.

In This Issue

[Intro by our President](#)

[World News](#)

[Publications](#)

[E-News Team](#)

Information Links

[Council](#)

[TIMS Home Page](#)

[Membership 2023](#)

[Our Bookshops](#)

[Click here for printable version](#)



During the week there was some preparation to do. I found an old piece of Yellowwood (this makes 18 different woods we've used so far!) and made a weight box to match the one in the photos from before the fire.

Yesterday we slipped it over the brake lever and fixed it down, then added the rocks (old broken granite bearings).



We were able to finish drilling the hole through the sheer and fit the vertical member.

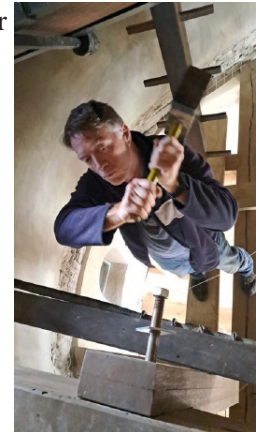

We could then attach the brake lever to the brake pole which we fitted when the crane was last on site. This took two attempts before we got the position right for the eye-bolt in the end of the pole.

We experimented with different lengths of chain and were eventually happy with this.



With that combination, we could attach the bracket I'd made in the week to the brake lever...

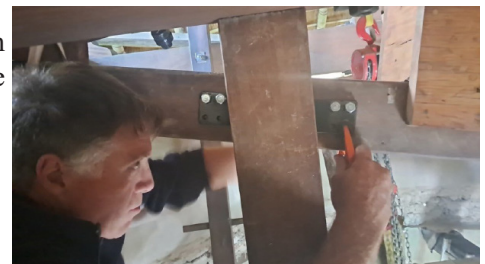

.... and then the 'BRAKE OFF' hook which this engages in, to the vertical member at a suitable height.



I can't drill straight, so in the week I made a smaller version of 'Abie', this one 8mm!

In This Issue

[Intro by our President](#)

[World News](#)

[Publications](#)

[E-News Team](#)

Information Links

[Council](#)

[TIMS Home Page](#)

[Membership 2023](#)

[Our Bookshops](#)

[Click here for printable version](#)



However the 'release device' was not working as hoped. In the week, I'd sanded away the top end of the Sapele block and cut a section out of the bottom to fit over the sheer, but the two mating faces I was hoping would slide over one another, being end-grain on both, wouldn't co-operate, even after applying Holsum vegetable-based margarine to both surfaces.

So I brought that home again and modified it, and on Jakes' suggestion, lined the top curve with a copper sheet.



When the upper brake assembly comes to rest on this it must slide slightly outwards to pull the brake away from the wheel. If this doesn't work, we'll cut a vee in this one and a corresponding one on the Jarrah piece above.



I was so confident in the brake now working, that I was all for leaving the mill without the restraining ropes on the sails.

However, Pilot John objected and we tied them down again as you can see in the first photo. A good move really in the storm we're enduring at the moment!

So we're nearly there with the brake! The next job is the millstones, now that the floors are being fitted by Kimon & Co. We drilled a hole for an eye-bolt in the upper beams over the lower ladder well.

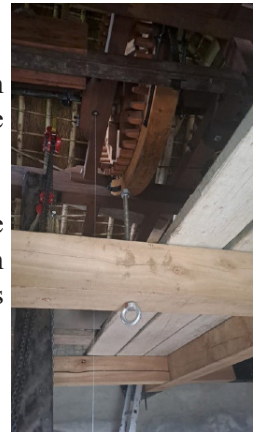

Part 18 Installing the Stones

7th October 2023

Hello all,

We got a huge amount done on Saturday 7th October at Mostert's Mill! We spread the word among the Friends that we'd be raising the 'new' millstones up to the stone floor, one up from the meal (ground) floor in our case. We also knew we'd need the curb down and in place



Charel on the right and Juan on the left unloading the tun they have made.



before the bedstone could be lowered into it, so Charel and Juan brought through the furniture as far as they've built it, as well as the stairs/ladders which they had just finished, to try out.

Thursday's photos, see my ropes on the sails? By Saturday morning, they had been stolen

In This Issue

[Intro by our President](#)

[World News](#)

[Publications](#)

[E-News Team](#)

Information Links

[Council](#)

[TIMS Home Page](#)

[Membership 2023](#)

[Our Bookshops](#)

[Click here for printable version](#)

The first thing I noticed when I got there was that some ##### had stolen my ropes that tied the sails down to rings in the ground, some time after a photo that Pilot John sent on Thursday.

A good job we completed the brake last time otherwise the thief might have been killed by the sails going out of control! We first had to test that the bedstone would fit in the curb, so we set up the sheerlegs and lifted it up off the pallet it arrived on.



Testing the curb over the up-turned bedstone.

We found in fact we have some clearance.

Setting up the curb dead centre to the plumb-line. Bearded Juan on the left, Straight Jon in the middle and Long John the Architect on the right. See why we have to have nicknames? Pilot John was downstairs



We first had to lift the curb up on to the stone floor and work out exactly where it must be, square to the floor beams and planks, and central to the plumb line from the pintle bearing in the sprattle beam.

Then we rolled the bedstone into the mill and hooked it up to the chain-block already hanging from an upper beam of the dust floor.

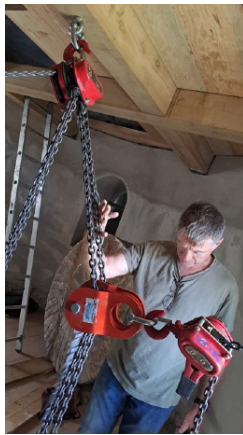

We set up another chain-block from a beam across the window, pulling on the lifting chains with two snatch-blocks, to hold the stone central in the stair-well opening.



The snatch-blocks were running on the lifting chains to hold the stone central in the stair-well opening.

The first lift, the bedstone, was not without problems. Half-way up we had to insert a heavy beam through the eye and rest it on the floor beams while we shortened the strop.

We ran out of lift just high enough to release the light chain-block from one side and use it to pull the stone over the edge of the sill of the floor from the opposite window.



Ready to pull over the sill with the chain-block from the other side window.

In This Issue

[Intro by our President](#)

[World News](#)

[Publications](#)

[E-News Team](#)

Information Links

[Council](#)

[TIMS Home Page](#)

[Membership 2023](#)

[Our Bookshops](#)

[Click here for printable version](#)



The runner came next; that was easy with what we'd learned with the first! I checked the time, we had both up by midday!

We then moved the curb back to our marked position; we had moved it out of the way while we lifted the stones, and we worked out where to drill through it for the four locating pegs, to come out in the middle of the beams below.



We had first marked the position of the curb on the floor, then moved it away while we lifted the stones. Then we moved it back and worked out where to drill holes for the locating pegs, to come out in the middle of the beams below.



The fourth hole killed my trusty Metabo drilling machine.



Locating pegs for the curb had to come out in the middle of the beams below. They need to be shortened slightly, so I had the square heads drilled off and we marked exactly how long each must be, with the wedge and a washer underneath. I'll weld the square heads back on at the appropriate lengths.



Charel (right) and Juan and their handiwork on the tun and horse!

We then tested out the tun and horse on the curb, we're delighted with the work of Charel and Juan!



Having checked some details and discussed finer points from photos, we dismantled the furniture and they took it back to their workshop here in Grabouw.

We tried out the stairs/ladders next. They don't need to go back to the workshop, there is just a bit of trimming to do. The upstairs ladder will have locating feet to hold it in place, and some trimming needs to be done at the top.

The Oregon they used for both the 'furniture' and the stairs/ladders came from a house on a farm here in the Elgin valley which was being demolished.



One thing will be very different, though: the downstairs ladder will have to stand across the door opening, where before it was in line with the east doorway. This is because the millstones are bigger than the originals and the curb will actually hang over the stair-well opening slightly.

In This Issue

[Intro by our President](#)

[World News](#)

[Publications](#)

[E-News Team](#)

Information Links

[Council](#)

[TIMS Home Page](#)

[Membership 2023](#)

[Our Bookshops](#)

[Click here for printable version](#)



The downstairs ladder will have to be across like this. Actually the access into the mill will be less obstructed!



We then got stuck into the next job, the preventer chains. Because the normal direction of turning, looking from the back, is clockwise, the left hand chain is the stronger, and straight with a simple D-shackle at each end, the right hand one has a turnbuckle to take up the slack.

We'll still fit three more pairs of eyes in the brake wheel so the sails can be 'put to bed' successively in the next position each time.

A good day's work!

And there we are no ropes needed and, look! No Millstones on a pallet or propped against the wall!
Compare this with Thursday's picture!



MESSAGE FROM THE E-NEWS TEAM

We hope that you have enjoyed this issue of E-News. We are dedicated to spreading this information to all mill friends, so please feel free to forward it to anyone who might also be interested. And remember, if you have any news items, short articles, books, announcements, photographs or anything else that you want to share, please send it to the editor, Leo van der Drift, lvddrift@telfort.nl. This Newsletter cannot exist without you! The next issue, No 36 is scheduled for March 2024.

