

---

No. 80, June 2010

---

# International Molinology

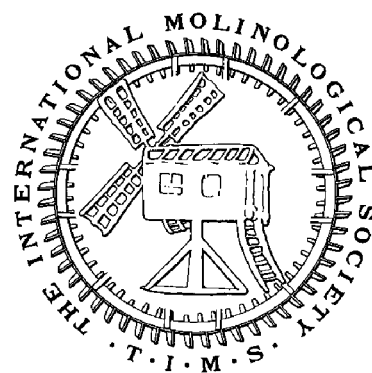

Journal of The International Molinological Society





The three restored windmills at the Cossack village initiated by Volodimir Nedyak. Photograph by Leo van der Drift.  
(See pages 2 and 3)



The Montefiore Windmill in a suburb of Jerusalem. (see page 39)

Int Molinology 2010,80.1

## Editorial

In this edition of *International Molinology* there is a report about the visit of the TIMS President, Willem van Bergen, and our two Dutch council members to a mill conference in Ukraine. The object of this visit was to raise the profile of TIMS in Eastern Europe and make contact with molinologists from that region with a view to eventually recruiting new TIMS members from these countries. At the other end of Europe, TIMS had recently sent all the members of the Irish national mill organisation details of TIMS in a bid to raise our membership in that country. Also a full colour, A4 size, poster has been sent to all the mills in Ireland that are open to the public to advertise TIMS. These actions are all part of a concerted effort to raise our membership, especially in countries where there have not been any, or very few, TIMS members previously.

**THE INTERNATIONAL  
MOLINOLOGICAL SOCIETY**



**Interested in mills worldwide?  
Find out more and join online at  
[www.timsmills.info](http://www.timsmills.info)**



TIMS poster showing Huven combined wind and water mill in Emsland, Germany

Another possible source of new members is the extensive Industrial Archaeology community where there are many people with an interest in mills, albeit not necessarily the traditional corn mill. As editor of IM, I am always happy to receive articles and items concerning the wider use of wind and water power in a whole range of industrial applications. This field is represented in this edition of IM by an article about mining with water powered

dredges and also one about the industrial use of wind power in 17th century Holland. Even the third article, about sugar mills in Jordan, can be considered as an industrial use of water power from the first part of the last millennium. Experience has shown that IM is a most useful aid for recruiting new members and certainly a wider range of articles will appeal to a wider range of molinologists. However, the best method of recruitment is still that of personal recommendation, which is how all members can assist in increasing the total number of TIMS members.

Another attractive benefit of TIMS membership is the *Bibliotheca Molinologica* series of publication. These are usually published at around a two year interval, although there has been a longer gap since the last of the BM series, *Boat Mills in Europe* by Daniella Graeff. Happily, I am now in the position, as TIMS editor, to confirm that the next publication in this series is scheduled for publication later this year. This major work, concerning the transfer of milling technology from the United States to Germany in the early 19th century, will be supplied free to all TIMS members as part of their membership subscription.

With this issue of IM I am now entering into my third year as TIMS editor and all I can say is that doesn't time fly when you are having fun! Certainly the six monthly deadlines for IM seem to come round quicker and quicker. Although articles for IM are not as scarce as they were in my first year, I am still looking for authors who wish to publish accounts of their research/experiences in the world of mills. One thing that I do need are those small items of mill news, or just short notes about something molinological that has interested you, that can be shared with our other members. The one task that usually gives me the most difficulty, surprisingly, is finding suitable relevant colour photographs for the cover of IM. So many articles by their nature are accompanied by mainly black & white photographs. Consequently if your contribution to IM includes a good quality colour photograph then there is a good chance it will feature on the IM cover.

On page 45 of this edition of IM there are two important items. The first is an advance notice of the next TIMS Symposium to be held in Denmark in 2011, so this is the time to pencil in the dates in your diary for this event. Full details of the Symposium and the pre- and post- Symposium mill tours will be published in the next edition of IM in December, together with all the details for making your reservations and transferring your payments.

The other item, sadly, is the obituary for Bill Howell. I first met Bill around the time of the Welsh Symposium in 1993 and Kate and I had the privilege of travelling with him to and from the last Symposium at Putten in the Netherlands. He was the last TIMS member, from the UK at least, who had a direct connection with making a living from watermills. My abiding memory of him from the last Symposium is standing at the doorway of a working watermill in Belgium, sniffing the air, and being able to tell exactly how much grain was being milled per week in the mill. He was quiet, modest and always cheerful and we will not see his like again.

Tony Bonson

Int Molinology 2010,80:2-3

## First International Molinological Conference in Ukraine

It was in the spring of 2009 that an invitation reached your Council to attend a 3-day molinological conference in Cherkasy, Ukraine, scheduled for 15th-17th October 2009. After some consultations, three members of Council, President Willem van Bergen, Representative for The Netherlands Ton Meesters and Secretary Leo van der Drift decided to accept the invitation and registered, with the aim of meeting new millfriends and promoting TIMS in Ukraine, one of the countries where it is felt that we still have too few members. And of course to visit mills in what was to us an almost unknown country!

Hosted by the Cherkasy Bohdan Khmelnytsky National University (Educational and Scientific Institute of History and Philosophy), this conference was part of a larger project "Reinstate Together" aiming at identifying, studying, increasing awareness and rehabilitating the windmills still left in Cherkasy oblast, south-east of Kiev. This fits in with the policy of the local government to promote tourism in the region by creating points of attraction. Windmills were once an important part of the culture here and this heritage should not disappear. According to a census from 1898, there were no fewer than 1600 windmills in this oblast alone! Today, about 30 windmills have been identified as still existing, a few in quite good order, but the majority, unfortunately, in a neglected or even dilapidated state. We would see several examples during the excursions that were made.

But first let us return to the conference itself. Around 50 people attended the conference, many of whom had come from other parts of the country. The three of us were the only participants from abroad. Many participants took a professional interest in mills, being scientists, museum curators or architects. After the opening ceremony and a welcome speech by the Director of the University, Prof. Anatoli Ivanovich Kuzhminski, the first day was fully devoted to presentations by the participants. The morning session was a plenary one in which Willem van Bergen was the first to take the floor and inform the audience about TIMS. We had brought some promotion material, a batch of

free copies of *International Molinology* and TIMS brochures, that were all handed out.

Ass. Prof. Vladimir Maslak of Kremenchug University presented the results of archival research. The oldest document found in which (wind?) mills are mentioned dates back to 1647. The Russian Czar granted permission to erect windmills at almost every village. As in many other countries, mills were an important source of tax income for the religious and secular rulers.

Prof. Vitaly Vasilovich Masnenko of Cherkasy University stressed the importance of studying mills from several disciplines. Little is known about what the first windmills looked like and how they spread. It is apparent, though, that there are many regional differences in construction.

Mrs Olena Krushynska held an interesting presentation on the architecture of wooden objects. The problem in Ukraine is that, as a result of a lack of information, people become indifferent and churches and mills will be neglected and eventually will be lost. Scientific research is good, but she warned against too much optimism: it is highly specialised and the information is available to only a limited number of people. She had started creating a website [www.derev.org.ua](http://www.derev.org.ua) dedicated to wooden architecture, with the aim of structuring and propagating information on wooden architectural heritage of Ukraine, as well as to attract public attention to the problem of its preservation. The website focuses on wooden churches, but in future will also include windmills. Several examples were shown.

Ton Meesters reported on his research on windmills in Poland. Together with Wessel Koster he visited over 500 sites over the last 8 years, mostly in Central Poland. All mills and mill remains were meticulously documented. It is a race against time, as the windmills in Poland disappear rapidly from the landscape.

Mr Sergei Verhofskyy of the National Museum of Architecture in Kiev mentioned numerous reasons for protecting and preserving the mill heritage. The museum has some 25 mills from different parts of the country.



**Fig. 1.** The interview at the television studio with TIMS Secretary Leo van der Drift on the left, TIMS Netherlands representative Ton Meesters in the centre, and TIMS President Willem van Bergen on the right with the interviewer and interpreters.

Mr Igor Oleksandrovich Odokisyko showed concern about the sad condition of many mills. We should not only study them, but at the same time actively restore the existing mills. From a technological point of view, this is still possible, and even from a financial point of view. We should see the mills alive again, thus bringing back the truly Ukrainian landscape, which is important when we want to stimulate tourism. A condition to be met for this approach is that mills must be added to the National Register of Monuments.

The afternoon had parallel sessions, so we had to choose where to go. One interesting presentation was given by Mrs Tanya Strykun, Director of the Bakhmach District Historical Museum. She gave an account of the importance wind- and watermills had had in the region. Windmills had predominated, and as many as 20 in a single village had been recorded. Winding the mills was often difficult, and up to 6 or 7 people were needed to do the job. Sometimes winding was done by animal power. She ended her talk by suggesting that we should return to the traditional mills, not only to preserve the culture, but also to preserve nature.

Mrs Olena Aleksandrivna Bokalo of Lviv Polytechnical National University presented a case study of three neglected watermills, all three huge wooden buildings, near Ternopil. These had recently been converted into smart apartment buildings, preserving and restoring as much as possible of the original components like sluices, waterwheels, pulleys, machinery, etc. According to the speaker, this had been the only way of preserving these mills, otherwise they would have collapsed and disappeared altogether.

We could not stay until the end, however, because an appointment had been made with ... the television studio! All of a sudden, Willem, Ton and I found ourselves sitting on a couch in Studio Plus, cameras all around, with a charming lady presenter and two charming lady interpreters. Broadcasted live, we were interviewed about TIMS, about our impression of Ukrainian mills and about the possibilities for the future. After 20 minutes or so, the organiser Dr Nazar Lavrinenko and three other conference participants took over from us and answered more questions for almost an hour. This certainly was an excellent way to promote mills and reach the general public!

In the evening a delicious conference dinner was served, according to tradition accompanied by a lot of spirits.

The second day took the party to a village on the other side of the Dnipro river. On private initiative, a new museum was being set up devoted to Cossack culture. It consisted of a museum building for exhibitions and an outdoor reconstruction of a Cossack village with thatched houses, barns, etc. To complete the picture, the initiator, Volodimir Nedyak, had bought no less than twelve windmills from neighbouring villages with the aim of transferring these to the museum grounds. At the time of our visit, three windmills had already been erected on their new site, while a fourth was under reconstruction (see photograph on the inside of the front cover). With this museum Mr Nedyak hopes to increase interest in and preserve Cossack culture. An excellent lunch with regional specialities had been prepared for us, while we were being entertained by a bard playing a traditional stringed instrument and singing old Cossack songs.

The third and last day we were shown a number of windmills around the town of Chyhyryn, south-east of Cherkasy. One of these, at Ivkivci, had been restored in 2008, as part of the "Reinstate Together" project.

During lunch, Dr Lavrinenko announced that a Ukrainian Mill Society was to be founded. This news was enthusiastically received by all. Let us indeed hope that such a society will create a platform for all those that care for the mills, and that can act as a serious partner in raising funds needed for the repair and upkeep.

Finally, we would like to thank Dr Nazar Lavrinenko and his team for the warm welcome and for the friendship throughout our stay. It is intended to organise a second conference in 2011. We certainly will attend again, and we hope to see some more TIMS members there!

For more information please consult the conference website at [www.mills.org.ua](http://www.mills.org.ua). The website is in Ukrainian, but don't be put off. By using the translate facility on your Google toolbar, the texts can easily be converted into English. Discover a new windmill world and enjoy!

Leo van der Drift  
Photographs by Ton Meesters.



**Fig. 2.** Willem van Bergen and Nazar Lavrinenko talking to the last miller of Hryshchynsi windmill.

## Current Wheel Dredges in New Zealand

Keith Preston

### Introduction

This paper commenced initially as a response to the article presented in *International Molinology* No. 77 (December 2008) *Boat Mills in New Zealand* which largely draws on an account of the gold dredging industry in New Zealand published in 1985. Due to the large volume of readily available material, mostly from contemporary sources, the work developed to form a further paper detailing the operation of current wheel dredges in the South Island during the period 1865 - 1905. Although the boat mills used for flour production in Central Europe share characteristics with the early New Zealand gold dredges, principally the adoption of twin wooden hulls anchored in mid-stream and current-operated ('paddle') wheels for power generation, the evolution of the gold dredge design is regarded as being allied more closely to established practices in alluvial gold mining and bucket dredge development worldwide. The term "current wheel dredge" first appeared in 1860s newspaper accounts and became widely adopted within the mining industry and in technical journals, being abbreviated to "current wheelers" during the 1890s. This term effectively describes the means of obtaining power and is considered to be appropriate in the mining context.<sup>1</sup>

The general operation of a bucket wheel dredge including the equipment used for separating the gold particles from the "wash dirt" recovered from the river bed is described in *IM77* (pages 28-29) and is not detailed further beyond outlining equipment used on individual dredges where historical records are available. The following account draws on primary sources (newspapers, mining journals, parliamentary papers) as well as secondary accounts (books, Department of Conservation reports) published since 1980 and unpublished information provided by Professor John McCraw who has extensive knowledge of mining history in the Otago region.

### Early Development (pre-1876)

The earliest reference found to the use of water power in the New Zealand gold dredging industry appeared in December 1863 when the Miller's Flat Dredging Company proposed fitting a small diameter paddle wheel to a "spoon" dredge to power an endless "chain of buckets" for conveying water into the sluice boxes. This was adopted by Franz Siedeberg and Charles Schultz for a new design of spoon dredge incorporating twin pontoons, becoming the third dredge to operate on the Kawarau River near Cromwell in April 1865. Siedeberg, and probably Schultz also, was a German immigrant who had worked on the Victorian goldfields at Ballarat, and it is therefore conceivable that he had observed working boat mills and adapted the twin hull concept. A 1.2 m diameter paddle wheel fitted with 200 mm wide float boards spaced approximately 300 mm apart (i.e. 12 floats) was positioned in the central well between the pontoons at the stern. A similar system is visible in the photograph of a spoon dredge operating on the Buller River on the West Coast (see Fig. 1) which shows the paddle wheel operating the endless chain of buckets of small capacity to lift water into the sluice box. The spoon (a bullock hide or cowhide bag attached to an iron ring) is located at the bottom end of the upright pole in the stern of the dredge and will be raised by means of the crab winch mounted at the bow.<sup>2</sup>

The adoption of the bucket-wheel pump for alluvial gold mining in the mid-19th century can be traced back to the gold rushes, initially to California in 1849 and later to New South Wales and Victoria in Australia in the mid-1850s and eventually to New Zealand. In June 1864 the *Otago Witness* reported that a "Mr Brown, late of Bendigo, Victoria, [Australia] has invented ... a water wheel to be driven by the force of the current alone" to work a "Californian pump" on his claim. This term was commonly used in Australia and New Zealand, the device being widespread for de-watering of relatively shallow underground workings. The bucket-wheel pump was in use

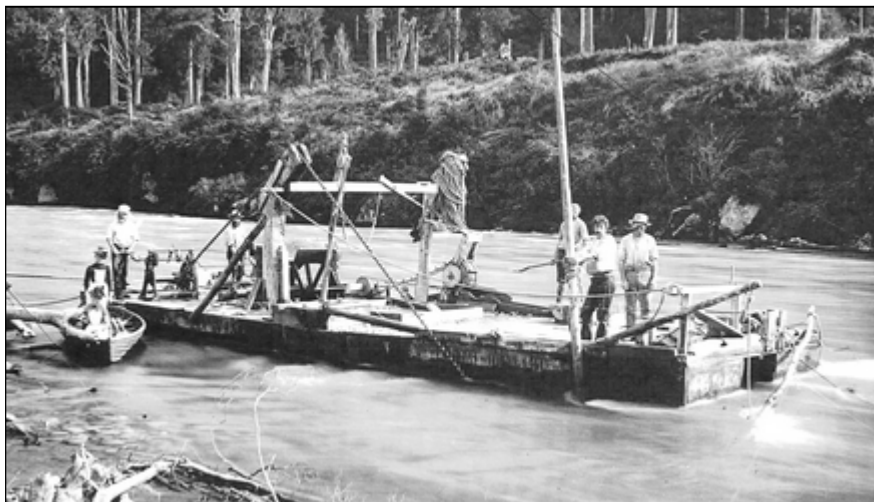

**Fig. 1.** Spoon dredge at work on the Buller River (West Coast of South Island), the Californian pump is positioned immediately to the right of the framework for the winch chain on the far side of the dredge.

during the Roman era being referred to in the works of Vitruvius and has been widely adapted in the ensuing 2000 years.<sup>3</sup>

The first dredge (the *Cerebus*, often reported as the Cerberus, see *IM77* page 27) incorporating paddle wheels of 3.4 m diameter to mechanize the raising of the river bed deposits by means of a spoon was designed by William Ward and commissioned in January 1866. The dredge was initially unsuccessful but evolved further following acquisition by the Moa Gold Dredging Co. in November 1868. A "ladder" (pivoted metal beam) fitted with a chain of metal buckets (an enlarged version of the bucket-wheel pump) was installed in the central well between the pontoons, thus establishing the basic configuration that was retained throughout the gold dredging era. In order to meet the increased power requirements, the wheel diameter was increased to 4.6 m and 13 buckets were initially fitted to dredge to a depth of 5.2 m. The dredge was also fitted with a rotating, perforated metal cylinder or "screen" for separating oversize material within the "wash", a technique that became widely adopted in the gold dredging industry. In March 1869 the dredge was working in shallow water of only 1.2 m depth raising was to a depth of 3.6 m. The following August it was reported as being repeatedly moved in search of payable deposits.<sup>4</sup>

The initial gold dredging boom that was dominated by spoon dredges lasted until the early 1870s when the shallow river bed deposits were worked out and the deeper deposits in midstream, where the faster flowing currents suited the current wheel dredges, remained out of reach particularly during the spring and winter when river levels were elevated. A further problem arose due to the river bed level in the slack water sections being raised as a result of the deposition of tailings generated both from alluvial mining along the river bank terraces and from upstream dredging operations. This was evident by 1873 when Franz Siedeberg gave up dredging. In the 1890 Mines Department report the rise in the river bed was noted to be at least 2.5 m in places.<sup>5</sup>

### Current Wheel Dredges Dominate (1876 - 1885)

A resurgence in dredging on the Clutha River during the mid-1870s led to dredges of increasing size and power being built with five or six current wheel dredges operating between 1877 - 1880. The *Salamander* was originally built as a spoon dredge in 1865 by Siedeberg, being converted to a current wheeler in January 1876 for McLellan, McKenzie & Co. The *Salamander* operated for only three years before sinking, this fate being a regular occurrence on the fast flowing rivers of the Otago district. As the operators slept on board overnight, McKenzie had to resort to an early morning swim to retrieve a row boat tied up on the river bank and rescue his partner who could not swim.<sup>6</sup>

A new dredge costing about £1000 was financed by Brazil & party and launched on the Clutha near Ettrick in August 1876. It was christened the *Luzitannia*, the wooden pontoons being built by shipwright William Jenkins of Port Chalmers, who was to be involved with many of the early current wheel dredges, and the machinery was supplied by William Wilson's Otago Foundry. Wheels of 4.3 m diameter were fitted to enable the bucket capacity to be increased

twofold, to 0.06 m<sup>3</sup> (2 cubic feet). The dredge worked until the end of 1884 when replaced by a larger dredge (the *Lusitania*) which was converted to steam power in February 1891. An additional 1.8 m diameter paddle wheel was added in May 1885 to enable the cradle to be rocked mechanically. This claim was located on a section of the river making between £30 - £130 per man per month but by September 1899 diminishing yields were reported as a result of the gold-bearing deposits becoming mixed with overlying gravel beds. Six weeks dredging the following December produced gold valued at £150.<sup>7</sup>

By March 1880 three current wheelers were operating at Miller's Flat and were joined in May by the newly commissioned *Duke of Sutherland* (*IM77* page 29) constructed using parts salvaged from the *Salamander* dredge. Reduction gearing was used to transmit the drive from the paddle wheel shaft to the drum mounted on the upper end of the ladder. In May 1882, five such dredges were working between Beaumont and Alexandra (forming 50% of the Otago fleet), including the newly-built *Hope of Dunkeld* (*IM77* page 29). This dredge was constructed by the William Jenkins-Kincaid, McQueen & Co. combination and commissioned in November 1881 for a syndicate of George Bennet (manager), John Donaldson, Archibald McDonald, J Heaps, Henderson and Andrew Smith. The dredge was working productive ground about 6.5 km south of Beaumont in August 1882 earning up to £40 per week and by May 1883 the proceeds were sufficient to engage six operators in continuous eight hour shifts.<sup>8</sup>

A financial interest in the venture was much sought after and by November 1882 Thomas Cairns had joined the syndicate as one of the dredge operatives. He was operating the dredge together with John Donaldson the following February when he was killed undertaking maintenance repairs to the ladder. The gearing had been disengaged to enable a displaced link between the buckets to be repaired. In order to remove a link or bucket, a 1.8 m long iron connecting rod weighing about 27 kg with a claw at each end was used to engage the links either side of the damaged section and prevent the entire chain of buckets slipping from the dredge. The following account of the tragic accident was reported by a correspondent of the *Tuapeka Times*:

"In consequence of the machinery of the dredge being stopped, the paddle wheels were being propelled at a tremendous velocity. It appears that Cairns had got the wrong end of the rod uppermost and was in the act of reversing it. Now, between the machinery and the paddle wheel there is not sufficient room to turn the rod without a certain amount of risk, the consequence being that whilst in the act of reversing the rod, the one end became entangled in the wheel, whilst the other end violently struck Cairns with tremendous force against the railing of the dredge ... the [slumped] body of Cairns was jammed between the dredge and the wheel, consequently he must have been killed before reaching the water."

Cairns financial interest in the dredge had been sold to Duncan McKenzie for £130 less than a month after his death. Another accident occurred in August 1888 when George Bennet was knocked unconscious while losing his grip on the wrench handle that controlled the lowering the dredge ladder.<sup>9</sup>

Three members of the syndicate that owned the *Hope of Dunkeld* (Henderson, George Bennet and Andrew Smith), commissioned another current wheeler, the *Excelsior*, in November 1882. This dredge was also to lose one of its partners, Andrew Smith a 45 year old native of Scotland, who drowned after falling overboard in December 1883 when working at McCunn's Beach some 8 km north of Beaumont. In September 1884 the dredge was idle due to the river level being too low and by about 1890 the dredge had been converted to steam power.<sup>10</sup>

The mid-1880s marked the hiatus of current wheelers when three more joined the Clyde fleet, another on the Kawarau River to the north of Cromwell and a fifth on the Pomahaka River to the west. The first steam dredge on the Clutha in 1881, the *Eureka* was built by the Wm. Jenkins - Otago Foundry combination for the Eureka Gold Dredging Co. formed by John Scott. Following the dredge being moved to Alexandra where a fast current prevailed, current wheels replaced the portable steam engine in June 1884, the reverse of the usual sequence of dredge evolution. The dredge was converted back to steam power in 1892 when a large diameter current wheel was retained to raise sluicing water for gold separation (see Fig. 2).<sup>11</sup>

Another of the Clutha dredges, the *Perseverance*, constructed for a syndicate of Louis Gards, Finlay, John McKersey and George Spencer became the largest dredge operating at that time when introduced in June 1886. The 26 m long pontoons were built by carpenter Gards using Australian blue gum for the frames and kauri from the North Island for the planking and decking. Paddle wheels of 6.1 m were fitted to power a 14 m long ladder fitted with 32 buckets of 0.08 m<sup>3</sup> (2.75 cubic feet). The resulting lift rate of wash shown in Table 1 of 27 m<sup>3</sup> per hour was over three times that of the *Duke of Sutherland* dredge, constructed six years earlier. An enlarged screen of 1.07 m diameter and 2.5 m length was required to handle the wash. A photograph of the dredge dated 1900 is included in *IM77* (page 29) after it had ceased operating, the dredge sinking at the mooring in April 1901.<sup>12</sup>

### Steam Competition (1885 - 1900)

Aitken & party were reported to have ceased operating the last current wheeler (at that time) at Miller's Flat on the Clutha River in May 1893 although three current wheelers remained on the southern sections of the Clutha and tributaries in November 1895 when 24 steam dredges were operating.<sup>13</sup>

A further phase of current wheel dredge construction occurred in the mid-1890s, commencing in September 1894 with the introduction of the *Maunherikia* following conversion from an unsuccessful pneumatic dredge venture by the Glen Rock Company, based in Melbourne, Australia. The pontoons and decking from the pneumatic dredge and the ladder removed from the *Dunedin* steam dredge were used by James Simmonds to form the basis of the new dredge. After being hauled 3 km up the river in March 1894, the dredge was moored overnight ready to commence work. The dredge was not adequately secured however, and as a result of a strengthening wind overnight, it drifted into the middle of the river, rolled over and sank. Simmonds undertook the salvage operation which entailed constructing a water race on the hillside above the dredge to provide sufficient pressure for jetting as a means of removing sediment from the pontoons. The dredge sank again at the beginning of June 1899 as a result of the seams opening in the wooden pontoons. A photograph of the dredge at work (see Fig. 3) shows safety boarding alongside the wheels, no doubt enforced by the Mines Inspectorate following the earlier accidents and at least one recorded fatality.<sup>14</sup>

The *Victoria* was built at a conventional wooden hull design, the pontoons built by William Duncan and the machinery supplied by the New Zealand Engineering & Electrical Co. of Dunedin, Alexandra. It was commissioned in December 1895 for a local syndicate of six partners headed by George Spencer. The gearing was described as the "heaviest ever used on a current wheel dredge ... the same as that erected on the *Perseverance*". The dredge was equipped with the largest recorded diameter wheels (6.7 m) and 0.06 m<sup>3</sup> (2 cubic feet) buckets (see Fig. 4). In a five knot current, the

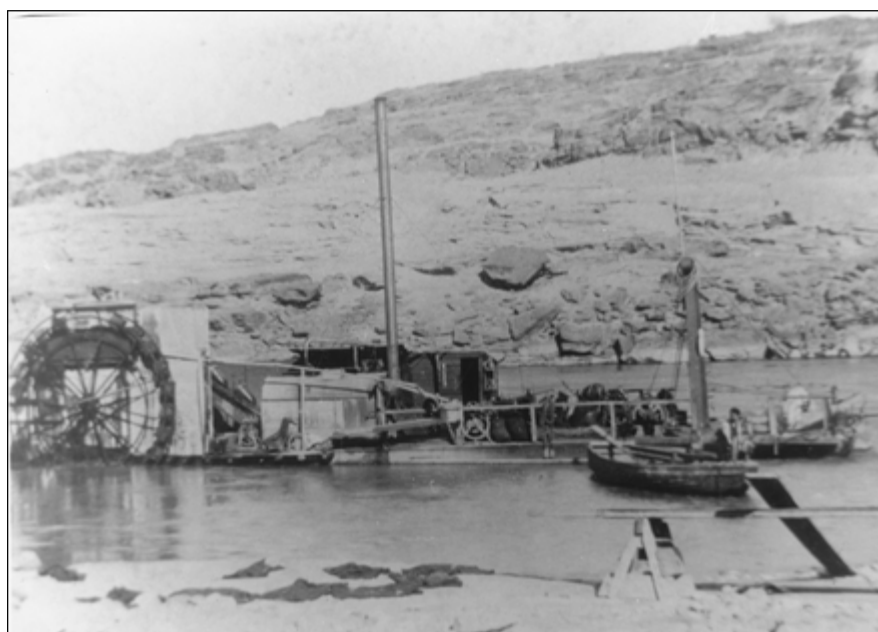

**Fig. 2.** *Eureka* dredge when steam powered and fitted with a large diameter paddle wheel fitted with buckets (likely dredge buckets) around the rim to raise water for processing purposes. (Reproduced by courtesy of John McCraw)



**Fig. 3.** *Manuherikia* dredge with paddle turning in a swift current and showing damaged float boards and small buckets for raising sluicing water around the inner frames of both wheels. (Reproduced by courtesy of John McCraw)



**Fig. 4.** *Victoria* dredge post-1897 in derelict condition near the old Alexandra bridge across the Clutha River, retaining only one paddle wheel frame.



wheels were stated to rotate at seven revolutions per minute and were estimated to generate 11 kW (15 h.p.) raising 37 m<sup>3</sup> wash per hour. Despite it being fitted with the most powerful paddle wheels up to that date, the dredge was described as unsuccessful “*being incapable of competing with the moving drift*” and was converted to steam in May 1897.<sup>15</sup>

In January 1896 the *Pride of the Clutha* entered service for Pringle & party at Miller’s Flat. The pontoons were built by William Jenkins and the machinery supplied by John Anderson of Dunedin at a total cost of £2500. Although Pringle’s claim adjoined that of Brazil & party and was described as producing rich returns, the dredge also became steam powered less than 18 months later.<sup>16</sup>

Dredge numbers in the South Island increased from 12 in 1886, all operating in Otago, to over 200 by 1900. The first dredges in Southland and on the West Coast appeared in 1887 - 1888 and formed 15 - 30% of the overall fleet through to 1902, thereafter increasing to exceed 40%. Otago therefore remained the dominant gold dredging region throughout the era of the current wheelers. During this period, the number of current wheelers operating in Otago reduced from about eight when they formed two thirds of the fleet, to one, the *Golden Falls* in 1901 - 1902 which was to become the last constructed.<sup>17</sup>

#### Swansong (post-1900)

The Golden Falls Gold Dredging Co. was floated in 1899 with a capital of £5500 which included an allocation of £4500 for construction of the largest and most powerful current wheeler to date (see Fig. 5). The overall pontoon dimensions were 7.6 m x 31.4 m and the inclusion of 3.5 m wide paddle wheels increased the operating dredge width to approximately 14.5 m. The ladder enabled dredging to a depth of 13.7 m and was fitted with 0.1 m (4 cubic feet) buckets, the machinery being fabricated in Melbourne by Johnson & Sons and the steel pontoons and erection of machinery undertaken by Knewstubb Bros of Port Chalmers, near Dunedin.<sup>18</sup>

The eminent mechanical and dredge design engineer, Francis Payne, incorporated radical design features including fixed, curved metal floats (along Poncelet design principles) in the paddle wheels to meet the increased power requirements and introduced a “water brake” to enable the rotation speed to be regulated without having to remove the floats. The entire operation of the dredge was stated to be water powered including the winches that were capable of working in reverse in order to raise and lower the ladder. Trials in a 6.5 knot current achieved a dredging

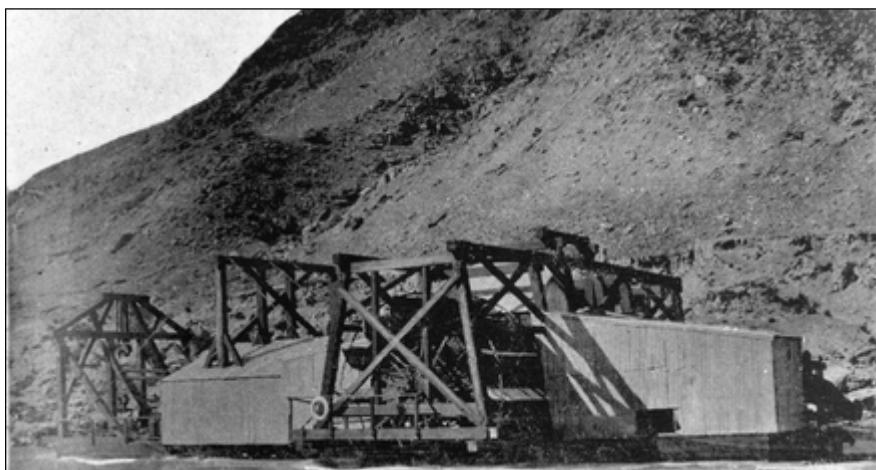

**Fig. 5.** *Golden Falls* dredge fitted with paddle wheels of increased width and curved steel floats. (Reproduced by courtesy of John McCraw)

rate of 10 - 11 buckets per minute, i.e. approximate dredge capacity of 70 m<sup>3</sup> per hour, requiring a screen of substantial proportions, 1.4 m diameter by 7.9 m in length, to handle the wash. Calculations indicated that a saving of £49 per week could be made over a steam dredge of comparable power of 22.4 kW (30 h.p.) due to fuel savings and reduced labour as up to three fireman could be required for 24 hour working.<sup>19</sup>

On completion, the dredge had cost almost twice the estimated amount requiring the shareholders capital to be increased by £2000 and topped up by a £1500 bank loan. The dredge was located on the company's claim in July only to find that the available current was insufficient to meet the power requirements due to a restriction in the gorge (known as the Molyneux Falls) downstream of the claim as a result of a rockfall. The reasons for this extraordinary oversight are not explained in contemporary sources but the implications are that inadequate communication took place between the design engineer and company directors conversant with site conditions.

Only £1000 was recouped when the dredge was sold to a consortium led by Dr. Hyde in October 1901, further trials being undertaken by the new venture now operating as the Molyneux Falls Gold Dredging Co. The current wheels powered the dredge until November 1902 when the dredgemaster was injured while lowering the waterwheel brakes which were controlled by a "rope wrapped around the shafts". Whilst re-engaging the gearing the rope slipped and Mr. Wilson received a blow on the head from the revolving handle. The Molyneux Falls Dredging Co. was floated the following month to raise £5000 to enable the paddle wheels to be removed and replaced by two oil engines of 16 h.p. and 25 h.p. The dredge had resumed work by March 1903 and continued until it sank in February 1905 when refloating was no doubt, an uneconomic proposition. Dismantling of the machinery was underway the following January which required an oil engine-powered winch to haul some 40 tonnes machinery 0.8 km up a steep river bank.<sup>20</sup>

The last current wheeler operating profitably on the Clutha River, excluding the *Golden Falls*, is believed to have been the *Manuherikia* which was worked until June 1899. As current wheelers were not introduced to the Mataura River until the mid-1890s, one at work near Gore for Evans & party and one under construction in October 1895, it is possible that at least one remained operational into the 20th century.<sup>21</sup>

### Paddle Wheel Design

The design of the paddle wheels employed on practically all of the current wheelers (with the exception of the *Golden Falls*) remained unchanged from the 1870s, incorporating a light-weight iron or steel frame with floats attached to each of the arms. On the *Duke of Sutherland*, iron framing of 15 mm x 35 mm section was used. The floats were flat, aligned radially and included provision for easy removal as the only means of regulating the rotation speed once the machinery was engaged or when the dredge was moored and not in use. Where details are available, between 12 - 14 floats were used, the depth of the floats being variable between 15-50 cm on the *Duke of Sutherland*. The floats appear to extend beyond the wheel frame in available photographs which makes the estimation of float width difficult.<sup>22</sup>

A trend of increasing size of paddle wheels is evident in Table 1 with wheels of increased diameter being utilized post-1880 in order to meet the increased power demands of larger dredges having longer ladders and hence increased dredging depth capability. Although the width of paddle wheels appears to vary in the photographic record that survives, limited data in the historical accounts prevents conclusions being drawn on any clear trend with time.

The first recorded application of buckets of sheet-iron construction being fitted to the paddle wheel rims to raise processing water for cradles, sluice boxes and gold saving tables (i.e. akin to a noria wheel for land irrigation) dates from 1880, when the *Duke of Sutherland* was commissioned. Water to operate a cradle was supplied "from one of the paddle wheels by tin buckets fitted on to the arms or spokes". Photographs of the *Perseverance* and *Manuherikia* dredges dating from the late 1890s clearly show small buckets attached to the inner frames of one or both paddle wheels where the arms intersect the rims. This practice was further modified on the *Excelsior* and *Eureka* dredges when converted to steam in 1890 - 1892, with enlarged buckets fitted around the rims of the large diameter paddle wheels (see Fig. 2.). The recorded dimensions of the buckets on the *Manuherikia* and *Eureka* dredges are approximately the same (36 x 31 x 20 cm = 0.02 m<sup>3</sup>) but a comparison of Figs. 2 and 3 suggests that those fitted to the *Eureka* were larger. The recorded capacity of the

buckets fitted to the *Excelsior* is “5 gallon” (0.05 m<sup>3</sup>), i.e. the same size as the dredging buckets and consistent with the those visible in the photograph of the *Eureka* dredge (see Fig. 2). Based on these examples, the practice of raising sluicing water using the paddle wheels appears to have become widespread by the 1890s.<sup>23</sup>

### Retrospective

Any assessment of the impact and relative success of the water-powered dredges must take account of the later development of the dredging industry during the boom that commenced in the mid-1890s following public awareness of the spectacular recoveries of some ventures and extended through to the end of WW1. The number and size of dredges increased dramatically, the additional power requirements met by steam and electric dredges with a corresponding rise in construction costs. The Mines

Department report for the year ending June 1899 records 96 dredges working or being moved in Otago and Southland with another 101 under construction. On the West Coast four dredges were operating and 58 under construction. When allowance is made for some redundancy of old dredges and stalled ventures, the South Island dredge fleet was set to double practically overnight and form the greatest concentration of dredges known. A significant number of the new dredges were engaged on the Clutha, data collected by McCraw indicating that within a 17 km radius of Alexandra, the dredge numbers rose from two in 1891 to a peak of 35 in 1903 (out of a total of 201 for Otago and Southland) before a gradual decline to one in 1920.<sup>24</sup>

The total number of current wheel dredges employed in the South Island is not precisely known but based on the database compiled by John McCraw, a maximum number approaching 40-45 is suggested when allowance is made for some duplication due to dredge names being changed following ownership change or re-

**Table 1. Notable Current Wheel Dredges**

| Name               | Operating <sup>(1)</sup> | Wheel Details (width/diameter) | Dredging Capacity   | Comments  |
|--------------------|--------------------------|--------------------------------|---|---|
| Cerebus            | 1/1866 - 12/1868         | 1.5 m x 3.4 m                  |   | Spoon dredge  |
| Moa                | 1/1869 - 1877            | 4.6 m dia                      | Depth 5.2 m<br>Buckets 0.03 m <sup>3</sup><br>Lift rate 13 m <sup>3</sup> /hr | Converted from spoon dredge   |
| Luzitannia         | 12/1876 - 1/1885         | 4.3 m dia                      | Buckets 0.06 m <sup>3</sup>   | Wm Jenkins/Otago Foundry  |
| Duke of Sutherland | 4/1880 - 12/1881         | 1.2 m x 4.1 m                  | Depth 5.8 m<br>Buckets 0.03 m <sup>3</sup><br>Lift rate 18 m <sup>3</sup> /hr | Kincaid, McQueen & Co   |
| Excelsior          | 11/1882 - c1890          | -                              | Depth 7.9 m<br>Lift rate 20 m <sup>3</sup> /hr                                | Kincaid, McQueen & Co<br>Converted to steam, one paddle wheel fitted for sluicing water |
| Eureka             | 6/1884 - 1892            | -                              | Depth 8.5 m<br>Buckets 0.05 m <sup>3</sup>                                    | Converted from steam<br>Wm Jenkins/Otago Foundry  |
|                    | 1892 - 5/1898            | -                              | Depth 11.0 m<br>Buckets 0.08 m <sup>3</sup>                                   | Converted to steam, one paddle wheel fitted for sluicing water                          |
| Perseverance       | 5/1886 - 4/1899          | 6.1 m dia                      | Depth 8.2 m<br>Buckets 0.08 m <sup>3</sup><br>Lift rate 27 m <sup>3</sup> /hr | R S Sparrow & Co<br>Sank  |
| Manuherikia        | 9/1894 - 6/1899          | -                              | Depth 9.5 m<br>Buckets 0.05 m <sup>3</sup>                                    | Converted from pneumatic<br>Sank  |
| Victoria           | 12/1895 - 5/1897         | 6.7 m dia                      | Depth 8.8 m<br>Buckets 0.06 m <sup>3</sup><br>Lift rate 37 m <sup>3</sup> /hr | Wm Duncan/NZ Engineering & Electrical Co<br>Converted to steam                          |
| Golden Falls       | 2/1901 - 9/1901          | 3.5 m x 6.0 m                  | Depth 13.7 m<br>Buckets 0.1 m <sup>3</sup><br>Lift rate 70 m <sup>3</sup> /hr | F W Payne engineer<br>Converted to oil engines<br>Sank 2/1905                           |

**Note:** Operating dates refer to periods when powered by current wheels with the exception of the Eureka where one paddle wheel was fitted in 1892 when converted to steam to supply processing water.

construction. Most were employed on the Clutha and Kawarau Rivers in Otago with a small number on the Mataura River in Southland. Although current wheelers were dominant up to the mid-1880s, they appear to have formed no more than about 10 - 5% of the overall industry number. As most current wheelers were privately owned by small syndicates, operating costs and returns were not divulged and a comparison of productivity with later publicly owned ventures is not possible. Reference to Table 1 indicates that the operational life of current wheelers was typically 5-10 years for successful ventures, the longest operating dredge believed to be that of the Kloogh syndicate between 1878 - 1898. As a result of the harsh operating conditions, extensive repairs or re-construction was often required within the ten year period.

The increased power provided by the larger steam dredges enabled the working depth to be increased to 15 m using buckets of 0.17 - 0.2 m<sup>3</sup> (6 - 7 cubic feet) by the early 1900s. Although deeper deposits untouched by earlier operations could be accessed, the increased operational costs, determined that higher recoveries exceeding 260 gm (20 oz) gold per week were required to maintain profitability. This explains the retention of current wheelers until the end of the 1890s to work the lower grade deposits and also to re-work claims previously dredged. In September 1898 a current wheeler was reported to have recovered gold worth £3570 during two months of the previous winter.<sup>25</sup>

During the early 1890s steam dredges were being built at a cost of £2500 - £3000 which compared to £2000 - £2500 for a current wheeler (*Pride of the Clutha*) of comparable size built during the mid-1890s. The cost of the steam engine and boiler for the Gunton Beach Gold Dredging Co. built in 1901 amounted to £615 forming almost 20% of the total dredge cost and thus constituted a considerable economic advantage for current wheel dredges. When the *Manuherikia* and *Perseverance* current wheelers were replaced by new steam dredges at the turn of the century, a capital raising of £10 000 - £12 000 was required to fund the ventures with £5000 - £6000 allocated to the contracts for dredge construction.<sup>26</sup>

Given the operational cost savings of the current wheelers over steam powered dredges, it is surprising that improved paddle wheel designs along the lines of those fitted to the *Golden Falls* dredge did not evolve earlier to enable parts of the river associated with reduced velocities to be worked by the current wheelers. By the time of Francis Payne's adoption of curved floats in the *Golden Falls* dredge in 1901, alternative hydraulic and hydro-electric power options were being introduced allowing alluvial deposits beneath the wide floodplains to be worked ("dry land dredging"). This dredging phase was to last another 60 years in the South Island and involve working depths of up to 20 m using 0.35 m<sup>3</sup> (12 cubic feet) buckets.

#### Acknowledgement

The provision of photographs (Figs. 2 - 5), a database of current wheel dredges and additional information supplied by Professor (Emeritus) John McCraw are gratefully received.

#### References

1. HEARN, T. J & HARGREAVES, R. P, *The Speculators Dream, Gold Dredging in Southern New Zealand*, Dunedin, 1985.
2. *Otago Witness*, 26/12/1863, p.5; 29/4/1865, p.14; 17/9/190, p.22.
3. *Ibid.*, 11/6/1864, p.19; 16/7/1864, p.10; GEORGIUS AGRICOLA, *De Re Metallica*, Dover Publications, 1950.
4. HEARN, *op. cit.*, p.4; CAYGILL, J., *A Chronology of Gold Dredging in Otago and Southland 1863-1889*, Dept. Lands & Survey, 13; *Otago Witness*, 16/1/1869, p.5.
5. *Mines Record*, Vol. 2, No. 2, p.62, Sept 1898; *Appendix, Journal of the House of Representatives of New Zealand* (AJHR), 1890 - C3, p.87; *Otago Witness*, 17/9/1902, p.22.
6. *Tuapeka Times*, 29/1/1876, p.2; 7/6/1879, p.3; *Otago Witness*, 3/4/1907, p.3.
7. *Ibid.*, 26/7/1876, p.2; 26/8/1876, p.2; 13/12/1884, p.15; 16/5/1885, p.3; 25/2/1891, p.3; *Otago Witness*, 5/9/1889, p.11; *Grey River Argus*, 9/12/1889, p.4; *Tuapeka Times*, 25/2/1891, p.3; *Otago Daily Times*, Aug 1899, p.53.
8. *Otago Witness*, 6/3/1880, p.9; 13/3/1880, p.9; 8/5/1880, p.9; 13/5/1882, p.12; 3/4/1907, p.26; *Tuapeka Times*, 3/12/1881, p.2; 9/8/1882, p.2; 23/8/1882, p.5; 26/5/1883, p.2.
9. *Tuapeka Times*, 28/2/1883, p.2; 24/3/1883, p.3; 1/8/1888, p.3.
10. *Ibid.*, 1/11/1882, p.2; 8/12/1883, p.2; 3/9/1884, p.2.
11. *Otago Witness*, 21/2/1885, p.8; AJHR 1895 - C3 p.154; McCRAW, J., *The Golden Junction, Episodes in Alexandra's History*, Square One Press, Dunedin, 2002, p.115.
12. *Otago Witness*, 14/5/1886, p.19; McCRAW, *op. cit.*, p.113.
13. *Tuapeka Times*, 17/5/1893, p.5; *Otago Witness*, 7/11/1895, p.18.
14. *Otago Witness*, 22/7/1897, p.17; *Dunedin Evening Star, Auriferous Otago*, p.16, 1899; McCRAW, *op. cit.*, p.74; Sinclair, R.S.M., *Kawarau Gold*, 1970.
15. *Ibid.*, 5/12/1895, p.17; 30/6/1897, p.3; *NZ Mines Record*, Vol. 2 No. 2, p.58, Sept 1898.
16. *Tuapeka Times*, 8/1/1896, p.3.
17. *Otago Witness*, 3/4/1907, p.26.
18. *Ibid.*, 6/3/1901, p.18; 5/7/1900, p.20; 14/8/1901, p.21; McCRAW, *op. cit.*, p.114.
19. *Otago Witness*, 27/2/1901, p.21.
20. *Ibid.*, 14/8/1901, p.21; 7/9/1904, p.25; 1/3/1905, p.28; 17/12/1902, p.25; 24/1/1906, p.34; *Colonist*, 31/10/1901, p.3; McCRAW, J., *Gold on the Dunstan*, Square One Press, Dunedin, 2003, p92-93.
21. *Ibid.*, 24/10/1895, p.17.
22. *Ibid.*, 8/5/1880, p.9.
23. *Ibid.*, 8/5/1880, p.9; *New Zealand Mines Record*, Vol. 3, No. 2, Sept 1899, p.57; AJHR, 1895 - C3 p.154.
24. *Tuapeka Times*, 3/10/1900, p.3; McCRAW, *Golden Junction, op.cit.*, p.126.
25. *New Zealand Mines Record*, Vol. 2, No. 2, p.61, Sept. 1898; SALMON, J. H. M., *A History of Gold Mining in New Zealand*, Government Printer, Wellington, 1963, p.237.
26. *Otago Witness*, 8/7/1897, p.20; 20/7/1899, p.21; *Tuapeka Times*, 3/4/1895, p.3; 3/4/1901, p.3.

Int Molinology 2010,80:11-25

## Alkmaar as the Nursery of Holland's Industrial Windmills around 1600

Herman Kaptein and Pieter Schotsman (†)

Translated by Leo van der Drift

*"It is surprising that the towns did not play a leading role in the rise of the industrial windmills"*  
 J. A. Kooren, "De Zaanse Industriemolens", in: B. W. Colenbrander and R. Schimmel (eds),  
*Molens in Noord-Holland*, Amsterdam, 1981, p.50.

### Introduction

When thinking of Holland's windmills, the polders and the Zaan area north of Amsterdam are what will come to mind first, that is mills in a rural setting. This is not surprising. Their reputation is derived especially from draining the large Dutch lakes and from their crucial contribution to the development of the Zaan area as one of the most industrialised country areas in Europe. Also today drainage mills are to be found predominantly outside the towns. Certainly, for the tourist, the Zaanse Schans offers the best place to visit industrial windmills such as saw mills, oil mills and dyewood mills. Of course many towns also still have their mills, in most cases tall tower mills with a reefing stage, but their number is limited and their function usually was grain milling. The fact that several towns have a much richer mill history is not always fully realised. In Amsterdam, for example, in the 18th century there were approximately 130 windmills working at the same time.



**Fig. 1.** In almost every town, one or more windmills with reefing stages can still be found that in most cases were used for grinding grain. Photograph by H. Kaptein.

This might be a disappointing number when compared to the 600 industrial windmills in the Zaan area, nevertheless it remains impressive when considered on its own. Other towns did not have near this number, although on all their ramparts windmills had been built.

Alkmaar also had its corn mills, drainage mills and industrial windmills, but apart from an old study of 1905 their history has never been systematically researched. Now that a thorough archival research of Alkmaar has been conducted the beginning of Alkmaar's mill history can be rewritten.<sup>1</sup> This paper, therefore, aims to map out the starting period of the industrial windmills at Alkmaar and in the province of Holland – nowadays divided into North and South Holland. It will be shown that the nursery of the Dutch industrial windmills was not in the countryside but in the town, the town of Alkmaar to be precise. This conclusion certainly evokes the question: why did a North Holland provincial town, without a marked industrial tradition develop into the first centre of mechanisation in several industrial branches using the wind as the motive power? To answer this question it is necessary to study different aspects of the Alkmaar society more closely. It is intended to gain greater insight into the factors that played a role in the introduction and the use of the technique of wind power in the early modern industrialisation of Holland.

### The Earliest Industrial Windmills - Initial History

When did the history of the Dutch industrial windmill begin? This question can be answered less simply than one would think. Usually it is dated at the end of the 16th century, when a number of technical innovations caused a genuine mill fever.

The year 1582 – the year in which the first wind-driven oil mill was erected, at Alkmaar – can thus be taken as a starting point. The mill history of the Zaan area is usually considered to have started in the year 1596, when the arrival of the first wind-driven saw mill set in motion a true revolution in the wood sawing and ship building industries. Depending on the definition of the industrial windmill, then the time boundary becomes blurred: industrial windmills are windmills in which raw materials are mechanically processed into goods for trading.<sup>2</sup> Corn mills, that usually ground the grain for the local citizens and bakers, are therefore excluded from this definition. However, in Amsterdam, which had developed during the 16th century into the central grain market of Europe, part of the meal was traded. Also, Zaan and Amsterdam corn mills were, at an early stage, producing for the bakers of ship biscuit for sea going vessels. Moreover, in towns with export breweries, grain millers could, temporarily or even completely, change to malt milling. Thus, even before 1570, the Haarlem

brewers had a specialised wind-driven malt/grist mill at their disposal and in 1573 permission was granted to their Amsterdam colleagues to establish one.<sup>3</sup> Apart from that single malt mill, Haarlem also had five tanbark mills before the beginning of the Dutch uprising against Spain (1568-1648). In these mills oak bark was ground into tanning-bark for the leather and sail/rope tanneries. The end products – leather for the hide merchants and cobblers, and tanned sails and ropes for the Haarlem ship building industry – also found their way outside the local and regional markets.<sup>4</sup> According to the definition described above, the Alkmaar oil mill of 1582 cannot be regarded as the first Dutch wind-powered industrial mill.

When looking at Alkmaar in this early period, there still is very little pioneering work to be discovered. For the few breweries and malt houses that were in the town around 1560 a special malt mill would have been superfluous because the grain millers could easily mill the malt as well as mill the grain.<sup>5</sup> Among the six mills that were in the town in 1561 one was a tanbark mill.<sup>6</sup> This mill was at the service of the town's fifteen leather tanneries, which no doubt also produced for surrounding markets. Apparently the leather industry was successful, because in 1569 a second tanbark mill was added.<sup>7</sup> Both were located outside the town walls and did not survive the Spanish attack on Alkmaar in 1573.<sup>8</sup> The first industrial windmill that was erected after the Spanish siege was, according to the above definition, not the well-known oil mill, but yet another tanbark mill.<sup>9</sup>

In other words: the mill revolution starting from the end of the 16th century had its initial history in the town's malt and tanbark mills, of which Haarlem was a more important

centre than Alkmaar. Because they did not supply large quantities of produce their significance remained modest. The technical process of this first generation of industrial windmills still did not use wind power in any innovative way in the industrial process. Crushing oak bark mechanically and milling malt did not essentially differ from grinding grain. Replacing the millstones was, in fact, the only thing that was needed to turn a corn mill into a malt or tanbark mill.

It will be clear that the wind could only become important as motive power in the production process when it could be used for multiple purposes. For this reason it is not the above definition of an industrial windmill, but rather the changes that took place in the technical processes that have been essential to the periodisation of the history of Holland's industrial windmills. From the end of the 16th century techniques that had been well-known for a long time – crank shaft, edge runners and pestles or stamps with camshaft – were used in Dutch windmills, thus enabling these to be used for a variety of purposes. Once mill construction itself had also been adapted to these activities and the productivity of the mill had increased by introducing several improvements, the technical conditions had been met for a far-reaching mechanisation of the production process.

The explosive growth in the use of wind energy for the new processes from the late 16th century onward is rightly considered as the actual start of the remarkable rise of the Dutch industrial windmill. The pioneering role of Alkmaar is in this phase, rather than in the initial phase. This does not mean, by the way, that the initial phase is without

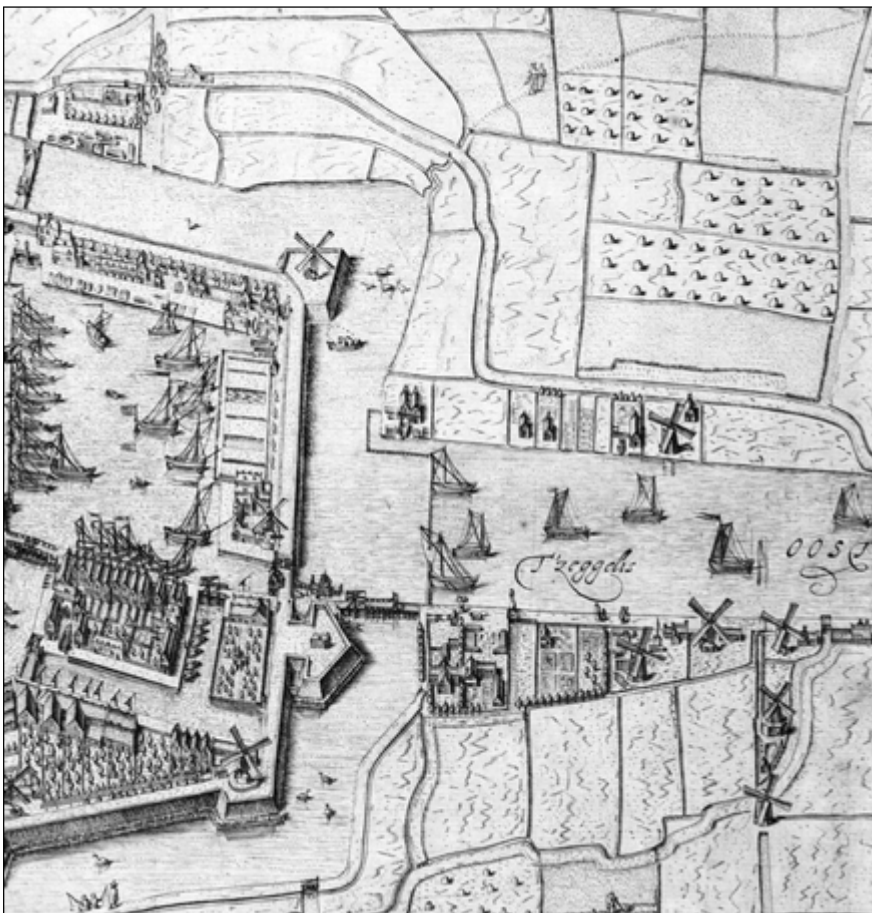

**Fig. 2.** The new industrial windmills on both banks of the Zeglis and on the ramparts at the eastern side of Alkmaar. Detail of a town plan of Alkmaar by Cornelis Drebbel from 1597. Source: Alkmaar Regional Archives.

importance: later on, when looking for explanations, this phase will be returned to extensively. But before this point is reached, Alkmaar's contribution to Holland's windmill history from approximately 1580 has to be determined.

### Alkmaar's First Industrial Windmills

In order to map out Alkmaar's contribution accurately, an inventory was made of industrial mills that were erected in the period 1580 – 1630 in Alkmaar and in Holland. This data – for Alkmaar derived from archival sources, and for the other towns and villages collected from published literature – have been brought together in Table 1 for a number of years. For reasons outlined above, tanbark and malt mills have been omitted. What is apparent from Table 1 is that between 1582 and 1596 Alkmaar had built industrial windmills of different types, and that for a long period Alkmaar practically held a monopolistic position. Before 1594 only one more industrial windmill was found outside Alkmaar: in Amsterdam (a dyewood mill), and only from this year did the Zaan area emerge as an industrial area. However, this is by far not the complete story. Although the attempt has been to be as complete and accurate as possible, there is no pretence to have completely succeeded. The source material and the data in the literature are not always unambiguous. Reports on mills can be very diverse by nature: a request to build one, granting permission or wind rights, the actual erection, modification, relocation or demolition of mills and changes of their owners or function. In addition, it is not always clear from archival records what kind of 'myll' is meant: one driven by wind, by horses (horse gin), or even by human power. It is therefore necessary to determine the exactness of the data, especially for the earliest mills.

### Oil Mills

In 1582, the Flemish immigrant Lieven Jansz was granted permission by the Alkmaar town council to put up an oil mill on the town's northeast fortification.<sup>10</sup> For a long time it is generally assumed that this mill was the first industrial windmill in Holland. Before 1582 only one other report of a

wind-driven oil mill in Holland is known. In 1564 Sybrant Appelman directed a request to the Amsterdam town council to allow him to erect outside the town walls an "oil mill, which was to be driven around and working by wind".<sup>11</sup> Because further details are lacking, it is not possible to check what happened with this request. Hence it is the Alkmaar oil mill that gets the credit of being the first.

Immediately after the town council granted permission in 1582, Lieven Jansz had an already existing oil mill moved from Flanders.<sup>12</sup> Although the privilege for this mill was granted only in 1588, it presumably will have started operations immediately.<sup>13</sup> However, an exact year of birth still cannot be determined with certainty. It is even possible that an oil mill in the village of 'Boschop' preceded the one at Alkmaar. In 1585 an oil mill had to be dismantled by the orders of the States of Holland, an order presumably resulting from the opposition of the towns against the rural industry.<sup>14</sup> It is therefore not determined incontrovertibly that Alkmaar indeed did have the first wind-driven oil mill. However, it does not much reduce Alkmaar's prominent role in the initial phase of this type of mill: in 1588 the only two Dutch wind-driven oil mills stood at Alkmaar, in 1593 the four sole oil mills stood there. It was only in the next year that another Dutch town – Amsterdam – followed suit and then in 1596 one stood in the Zaan area.<sup>15</sup>

### Paper Mills

Around 1600 the centre of the paper industry in which mills were involved, lay rather in South Holland than in North Holland.<sup>16</sup> At that time there were six paper mills in the South and three in the North, two of those being in Alkmaar and one in Amsterdam. However, the paper mills in the river delta area in the South were not windmills, but tide mills. These are watermills of which the wheel is turned by the force of water flows as a result of the difference of high and low tides. The first paper mill in Holland in 1586 was in fact a tide mill. Hence the Alkmaar wind-driven paper mill, which received its patent right later in the same year and was erected within a year, can be rightly regarded as the first of its kind in The Netherlands, and even in the world.

**Table 1:** Numbers of industrial mills at Alkmaar (A) and Holland without Alkmaar (H), 1593, 1596, 1614 and c.1630

|                      | 1593 |   | 1596 |   | 1614 |    | 1628/30 |     |
|----------------------|------|---|------|---|------|----|---------|-----|
|                      | A    | H | A    | H | A    | H  | A       | H   |
| Oil mill             | 4    |   | 4    | 3 | 6    | 12 | 4       | 69  |
| Paper mill           | 2    |   | 2    |   | 3    | 7  | 2       | 11  |
| Fulling mill         |      |   | 1    |   | 3    | 2  | 2       | 14  |
| Saw mill             |      |   | 1    | 4 | 2    | 13 | 3       | 85  |
| Hemp mill            | 1    |   | 1    | 1 |      | 8  |         | 9   |
| Rope fulling mill    |      |   |      |   |      | 3  |         | 2   |
| Dyewood mill         |      | 1 |      | 1 |      | 2  |         | 2   |
| Gunpowder mill       |      |   |      |   |      |    |         | 7   |
| Buckwheat mill       |      |   |      |   |      |    |         | 5   |
| Copper mill          |      |   |      |   |      |    |         | 2   |
| Washing blue mill    |      |   |      |   |      |    |         | 1   |
| Scouring powder mill |      |   |      |   |      |    |         | 1   |
| Mustard mill         |      |   |      |   |      |    | 1       |     |
| Total                | 7    | 1 | 9    | 9 | 14   | 47 | 12      | 208 |

The central figure in the rise of Alkmaar as centre of paper production was Jan Jacobsz du Bois. On 21st April 1586 he was granted permission with substantial concessions by the Alkmaar town council to erect a windmill outside the town walls to process raw materials from which paper could be produced.<sup>17</sup> When he was granted the privilege on 8th June 1587, the mill had already been built. In 1604 there were three wind-driven paper mills and one driven by horses in Alkmaar.<sup>18</sup> Thus Alkmaar had already been the centre of paper production in North Holland for a considerable time before paper mills appeared in Amsterdam (1598) and the Zaan area (shortly after 1601).

### Hemp Mills

The first reference to a Dutch hemp mill is found in the description of an invention: in 1589 the inventive Amsterdam town secretary, Dr Albert de Veer, received a patent for an “*instrument serving to beat and soften the hemp with stamps powered by a turning mill mechanism*”.<sup>19</sup> This patent focussed on the stamp mechanism, not on the mill. According to the further description of the patent, this mechanism could be set in motion by “wind, horses and water”. It is, therefore, not likely that the “mill mechanism” was already built and/or operating at the time the patent was granted, let alone that this indicated the first wind-driven hemp mill. The first references to wind-driven hemp mills in Amsterdam are of a later date: namely 1595 and 1597; and to a Zaan hemp mill in 1600.<sup>20</sup> In a hemp mill stems of hemp were pounded to make the fibres suitable for weaving sail cloth and for making rope. For this reason the first Zaan hemp mills were located in the centre of the sail cloth weavers, in the villages of Krommenie and Assendelft. Goudsblom mentions a “hemp-clop mill” at Assendelft from 1583 but also states that this was not necessarily a windmill.<sup>21</sup> Returning to Alkmaar, this town again seems to have the best testimonials. A wind-driven hemp mill which was granted a building-permit in 1591, was completed in the same year on a piece of land outside the town.<sup>22</sup> The two owners were not Alkmaar citizens, however, but inhabitants of the Zaan village of Wormer.<sup>23</sup> This mill worked for the hemp industry until 1610, when the mill was converted into a fulling mill.<sup>24</sup>

### Fulling Mills

On 16th January 1595 Gerrit Claasz Schuijt received permission from the town council to build a fulling mill for the woollen or draper’s industry.<sup>25</sup> Fulling woollen cloths was a labour intensive occupation and served, depending on the type of cloth, to felt or clean the fabric. The purpose of felting was to shrink the fibre structure thus making the cloth more dense. The result was a smooth, strong and windproof woollen fabric. The purpose of cleaning was above all to scour the fabric. Without doubt the request by Schuijt concerned a horse-driven mill, because he was allowed to erect it in his back yard inside the town. Although a novelty to Alkmaar and Schuijt requesting temporary exclusive rights – in vain, the first horse-driven fulling mills in Holland had in fact already appeared earlier. A very early example was at Haarlem from around 1530, erected after a working visit to Mechelen. In other Dutch clothmakers towns this type of mechanisation was introduced towards the end of that century when immigrants from Flanders

came into Holland.<sup>26</sup> Wind energy in the fulling industry was introduced in Holland outside Alkmaar only after 1611, for instance at Leiden, by far the most important cloth town in Holland, in 1619. This relatively late development of the wind-driven fulling mill was partly due to the patent right which Alkmaar had been granted for this industry.

Schuijt’s horse mill did not become reality, because in its place a wind-driven fulling mill was built. In the years 1595-1596 Schuijt entered into a partnership with Maerten Pietersz van der Meyde. On 8th September 1595 this man, a former town’s carpenter and then timber merchant in Alkmaar, was granted by the States of Holland a patent for 15 years for a windmill designed by him for fulling cloth and hammering copper.<sup>27</sup> The collaboration between Schuijt and Van der Meyde resulted in the first wind-driven fulling mill in Holland. It was, presumably, put into operation early in 1597. Exactly fifteen years later and after the term of the patent had expired, a request by the village of Voorburg near Leiden to erect a fulling mill – presumably a windmill – was turned down by the States of Holland. In the same year 1612, however, such a mill was built at Edam.<sup>28</sup> Meanwhile the patent right holders of the wind-driven fulling mill were able to further extend their activities both outside and inside Alkmaar. Six months after Van der Meyde had obtained his patent in Holland, he received one for the district of Utrecht.<sup>29</sup> Thereupon, on 16th July 1596, he was granted permission by the town council of Utrecht to erect a smock mill. Although this mill was also able to hammer copper and even to full leather, it appeared that in 1602 it was used as a [cloth] fulling mill. Whether this Utrecht wind-driven fulling mill was in operation earlier or later than the one at Alkmaar is unknown.

In the year 1608 the Alkmaar patent holders granted permission to two men from Wormerveer to build a fulling mill in the Zaan area.<sup>30</sup> Alarmed by this news and apprehensive of competition from the rural area, the Alkmaar town council informed the district authorities in order to prevent the building of this mill. The town council took their advice and tempted the said men successfully to Alkmaar to erect their mill on Alkmaar soil in return for some financial compensation. In 1609 they, and an Alkmaar citizen, were granted privilege for this mill. In the same year the Alkmaar patent holders were granted privilege themselves for a second fulling mill; this concerned the converted Alkmaar hemp mill. Thus Alkmaar already possessed three fulling mills before they appeared in other Dutch towns.

### Saw Mills

In 1596, a wind-driven saw mill named ‘*Het Juffertje*’ (‘The Missie’) was brought to Zaandam on a raft. For the Zaan area, this was the start of a revolutionary development of mechanical wood sawing which served primarily the large-scale ship-building industry. In 1630 there were already 53 wind-driven saw mills in operation in this rural area north of Amsterdam. ‘*Het Juffertje*’, designed and built by Cornelis Cornelisz of Uitgeest, would have been the first of this great number. This explains the great importance that is attached to the aforementioned occasion when ‘*Het Juffertje*’ was moved. But was this really the very first wind-driven saw mill that worked in The Netherlands, and thus in the world? For a long time there has been uncertainty about



this because of information from Alkmaar. On 16th January 1595, one year before 'Het Juffertje' was moved, the Alkmaar town council had decided to give the same Cornelis Cornelisz, at his own request, a piece of land to erect a wind-driven saw mill.<sup>31</sup> The uncertainty lies in the question of whether this Alkmaar mill actually had or had not been built. Recently it has been determined incontrovertibly that the windmill was indeed built within the year 1595.<sup>32</sup> However, was this Alkmaar mill the earliest constructed wind-driven saw mill?

Cornelis Cornelisz received the patent for his wind-driven saw mill from the States of Holland on 15th December 1593.<sup>33</sup> The mill for which he had requested the patent rights still had to be built. The construction drawings, which he had added to his request, show a hollow-post mill. This mill only housed the gearing. A long horizontal shaft connected the mill with a shed in which the sawing equipment was housed. The shaft ended there with a crank shaft thus changing the rotational movement into a reciprocating movement of the saw frame. In addition, he had discovered a way to move the trunk or log automatically towards the saw frame during the sawing process. He could have built and tested this model in 1594 at the earliest, possibly together with his neighbour who was a carpenter. Perhaps this is the mill that was brought to Zaandam two years later. However, it could also have been another version of it, because the inventor kept adjusting his design, so that on 6th December 1597 he was granted the patent rights for ten years for an improved design.<sup>34</sup> This concerned mainly the new crank shaft construction, but it is also striking that the mill had become a hexagonal or octagonal smock mill. This shape corresponds with the Alkmaar saw mill from 1595. In addition, the patent now stated that the new design had proved itself already. In other words: the first Alkmaar wind-driven saw mill was an improved version of the original idea of Cornelis Cornelisz.

If it was not the earliest constructed, then had the Alkmaar mill been the first that was actually put into operation? Or was Cornelis Cornelisz himself the first to exploit his own invention economically? It is possible, because in 1593 he characterised himself as a poor peasant, but in 1598 and 1602 he called himself a sawyer.<sup>35</sup> Nevertheless it is suspected that in the early years he was more a millwright than an operator of (his) mills. He sold his mills and allowed others to build mills according to his patent on payment of a royalty. After being built, the Alkmaar mill too turned out not to belong to him but to two Alkmaar citizens.<sup>36</sup> In these early years Cornelis Cornelisz certainly would have worked his mills, but rather to experiment than to build up a wood sawing enterprise. Moreover, his creativity was not limited to saw mills. In his second Dutch patent from 1597, he received protection for his invention of the edge runner for use in oil mills, according to which the seeds were not crushed by stamps, but by stones turning on their edge. In short, it seems very much likely after all that after the experimental phase in which Cornelis Cornelisz tested his saw mill(s), the first wind-driven saw mill in the world that was put in operation stood at Alkmaar in 1595.

In conclusion: of all the important types of industrial windmills at that time, Alkmaar seems to have the best testimonials as the nursery. Although elsewhere in Holland there are signs that could point to an earlier or simultaneous

introduction (oil mill, hemp mill and saw mill), these are too weak to nominate them as candidates. The first industrial mills in Alkmaar are the only ones where their existence as producing mills has been proved. Until approximately 1595 Alkmaar was the absolute centre of the industrial windmills in Holland. Only after having proved in this town their right to exist, industrial windmills appeared in other towns and villages. Naturally, this remarkable position requires an explanation. Before looking into this extensively, another question can be raised: to what extent was Alkmaar the first in this field, not just in Holland, but also in The Netherlands and in Europe?

### Wind Energy in Europe and in The Netherlands

For a number of types of industrial windmills, the area of origin must not be sought in Holland, but in Northern France and Flanders. One of the oldest processes using the wind as motive power over a vast area and on a large scale is the stamping of oleaginous seeds. Thus a Flemish windmill privilege register from 1467 shows how early this region was an important centre of wind-driven oil mills.<sup>37</sup> According to a late 16th century Flemish register four wind-driven oil mills were erected and two were relocated in this region during the years 1574-1575.<sup>38</sup> This was at least eight years before the first oil mill was built at Alkmaar. In addition, elsewhere in The Netherlands oil mills had already been reported. In 1566 the States of Friesland received two requests for the erection of wind-driven oil mills. Both requests were granted, also it is certain that one of these was actually built.<sup>39</sup>

The earliest recorded wind-driven fulling mill is found in 1564 at Saint-Jans-Cappel, a village in French Flanders.<sup>40</sup> In The Netherlands the town of Groningen preceded Alkmaar in the field of fulling by wind power: in 1578 the wool-weaver Wessel van Munster received permission from the Groningen town council to erect his wind-driven fulling mill in the town.<sup>41</sup> Thus Maerten Pietersz van der Meyde was not its inventor. A drawing of a wind-driven saw mill from 1584 by Jean Errard makes it clear that even Cornelis Cornelisz had his predecessor as the inventor of the wind-driven saw mill.<sup>42</sup> Born in the north-east of France, an area rich in water-driven saw mills, Jean Errard recommended his 'new machine' as an alternative in case there was a shortage of water. There are no indications, however, that it was actually in production. Therefore, Cornelis Cornelisz can be given the benefit of the doubt and take the credit for having built the first saw mill which was actually used as a working mill.

All this indicates that Alkmaar was not the first place in The Netherlands to use wind energy for oil mills and fulling mills. As for other applications, nowhere in the world have predecessors been found of the Alkmaar wind-driven paper, saw and hemp mills. The remainder of this article will focus on the question as to why it was a small town like Alkmaar that was the first to experiment with wind power for different sorts of processes.

### Water and Wind

The use of a technical innovation does not result from necessity.<sup>43</sup> Nor is the practical use of an innovation immediately obvious to a contemporary. In addition, a society is not always susceptible to a specific innovation.



**Fig. 3.** Alkmaar was surrounded by water. In the 16th century, a number of small lakes were reclaimed using drainage mills, thus experience was gained with windmill techniques. The wind coming from the North Sea was powerful. Plan by Jacob van Deventer c.1560. Source: Alkmaar Regional Archives.

However, at a certain moment when it is, it will have to select from a variety of types of tools and machines and perhaps adapt these to local conditions. Even when a technical instrument is fully developed and is available completely free, it is not applied as a matter of course. For this process of rejection, acceptance and selection there is no general and unambiguous explanatory model. For a clear comprehension, one therefore has to study the specific circumstances for every time and place.

Explanatory factors can be found in geographical, cultural, economical and socio-political fields. Moreover, in the case of Alkmaar, it has to be born in mind that the town was developing into a pioneering area in Holland. This town took the first initiatives in the field of wind-driven industrial

mills and dared to take risks, whereupon other towns followed. Therefore, it is necessary to look for specific factors that did not play a role in the surrounding areas or at least only to a lesser extent.

#### Climatological and Geographical Circumstances

It is very remarkable that industrial mills spread in North Holland, whereas industry was concentrated in South Holland. The availability of water power in the South Holland river area no doubt will have been an obstruction to the rise of wind energy here. For the North Holland towns, where water power was not an option, the choice for wind was not an automatic matter of course around 1600. Horse



**Fig. 4.** Drainage mill *De Geestmolen* at Alkmaar, built c.1560, is among the oldest preserved octagonal smock mills in The Netherlands. Photograph by H. Kaptein.

mills could have been used without any problem, as the drapers had done for fulling their cloth at Leiden in 1585 and in 1590, at Rotterdam in 1591 and at Haarlem, first around 1530, and later in 1598.<sup>44</sup> In this early stage of development the application of wind energy in the industry still had too many uncertainties for it to be used abundantly.

What persuaded entrepreneurs, among other things, was the availability of sufficient wind power. North Holland is surrounded by water, the North Sea being on the western side and the Southern Sea (now IJsselmeer) on the eastern side. The force of the prevailing westerly winds off the sea was, of course, highest in the coastal areas and decreased rapidly more inland.<sup>45</sup> The position of the Alkmaar windmill area was very favourable being a distance of about 10 km from the coast and situated by the open waters of the Zeglis. This was a significant factor but by no means the only one. For instance Haarlem, with its important shipyards and textile industry, is situated in the same wind belt as Alkmaar. Therefore the earliest wind-driven saw, hemp and fulling mills might be expected to be found in Haarlem rather than Alkmaar.

A second important reason for the appearance of the earliest industrial windmills at Alkmaar was its rich experience and familiarity with drainage mills. The town was not just situated in the vicinity of a few large lakes, but was also surrounded by many smaller lakes. Harnessing the water here had been a structural problem for centuries and all available means had to be employed in order to prevent floods. Of course, Alkmaar was not the only town that experienced these problems, everywhere in Holland the cultivation and use of the peat areas of which it largely consisted, caused an on-going sinking of the land and a continuous threat from the water. But at Alkmaar and its surroundings, the circumstances were such that the struggle against the water led to two novelties in public waterworks history.

Around 1408 the first experiments with wind-driven drainage were held here. The natural drainage by letting the surplus water flow from a high to a lower level of water was replaced by an artificial outlet for discharging the surplus water into a higher lying storage basin by means of a windmill equipped with a scoop wheel.<sup>46</sup> Over a century later wind power was not only used to protect the land against the water, but also to reclaim land from the water: in 1533 the first reclamation of a lake, the Achtermeer, close to Alkmaar, was completed.<sup>47</sup> Soon other lakes in the vicinity followed at an accelerated pace, culminating at this stage in the reclamation of the Egmonder- and Bergermeer around 1565. As a result of these successive reclamations and the drainage of the polders on a daily basis the Alkmaar people acquired a lot of experience with the newest windmill techniques.

In this respect consider the perfection of the well-known Dutch octagonal smock mill, a thatched wooden mill with a rotating cap. The earliest record of a North Holland smock mill is that of two Alkmaar drainage mills built in 1532/33 by three Alkmaar carpenters.<sup>48</sup> Around 1565 an octagonal smock mill was used, assisted by two hollow-post mills, for the reclamation of the Bergermeer.<sup>49</sup> They were sufficiently powerful to be able to master the head of one meter, which was rather high for that time. How this last smock mill looked like can be seen from the still existing Alkmaar drainage mills '*De Geestmolen*' dating back to approximately 1560 and '*De Viaan*' from approximately 1580.<sup>50</sup> These two mills are among the oldest surviving smock mills and they prove that the Dutch smock mill had

already reached an almost perfect method of construction before 1600.<sup>51</sup> The development of this powerful and robust mill-type has been of the utmost importance for the history of the industrial windmill in Holland. This type of mill could offer more power and greater working space for the mechanical processing of raw materials than other types of mills, such as the post mill and the hollow-post mill. Around 1600, the Dutch smock mill was quite rapidly becoming the dominant type of industrial windmill, together with the later developed paltrok mill.

In conclusion, because of the location of their town in a very favourable wind belt and in a wetland, and as a result of their rich experiences with polder drainage, the Alkmaar people were already familiar with windmills at an early date. Therefore, it may be expected that Alkmaar society had a more than average interest in the newest industrial applications of wind energy. Further, their familiarity with mill construction found expression in an active contribution to a number of innovations. Therefore these technical developments will be studied in more detail in order to find more answers to the question as to why Alkmaar was the centre of the industrial windmills in Holland, if only for a short period.

### Inventors and Inventions

Technical innovations are not the mere creations of brilliant inventors.<sup>52</sup> Usually they are the result of a process of small changes made by mainly anonymous minds. Only a few amongst them have acquired a place in the history of technology. In the general perception someone is usually given the credit for a complete innovation, although they may only have completed a particular device or employed an existing device in a new application. Also someone, who merely introduces a device developed elsewhere, is often seen in the popular mind as its inventor and therefore they appeal to the local, regional or central government for patent rights. For a certain period and in a specific area this would give the exclusive right to exploit this innovation for profit and/or to let others use it on payment of a royalty. Too often the patent applicant was subsequently considered to be the inventor of the device.

Applying this scenario, it can be stated that the breakthrough of industrial windmills in Holland before 1600 was not accomplished because of new inventions. This also concerns the innovative devices that Cornelis Cornelisz of Uitgeest first applied in the saw and oil mills. For instance, his crank shaft, the mechanism by which the rotative movement of the sails was transferred into a reciprocating movement of the saw frames, was not a new invention, because examples from the 15th century are known.<sup>53</sup> The edge runner in his oil mill, vertical millstones that roll on top of a horizontally one to crush oleaginous seeds, were known in Europe since Roman times. It is also necessary to take into account that in The Netherlands, edge runners for seed crushing were already in use in water driven mills half a century before the edge runner patent was granted to Cornelis Cornelisz (1597).<sup>54</sup> Before the introduction of the edge runner in the Dutch wind-driven oil mill the process was accomplished by means of camshafts that lifted wooden stamps one by one and then let them fall again. But this stamping mechanism had also already been in use for a long

time in water-driven mills for several purposes.<sup>55</sup> The fact that the patents of Cornelis Cornelisz did not describe new inventions does not, however, in any way detract anything from the merits of the ‘poor peasant’ of Uitgeest: it fits within the pattern of a continuous process of small technical changes in varying circumstances. Therefore the major significance of Cornelis Cornelisz and other practical innovators is not based on the creation of new devices, but rather in the introduction in the new industrial windmill of devices used elsewhere.

Thus transmission of knowledge from country to country was of essential importance and took place in several ways.<sup>56</sup> There are a number of ways this was achieved. Firstly there was ‘technological tourism’ or industrial spying, visiting and inspecting technical novelties in other areas and other countries. A second means of transmitting knowledge were illustrations and descriptions in books about technology. Thus, at the end of the 16th Century the first series of retrospective works were published in the surrounding countries containing a survey of all kinds of technical instruments with detailed descriptions and accurate copper plate engravings.<sup>57</sup> In one of these, namely that of the Frenchman Pierre Besson in 1578, an illustration can be found of a human-powered wood sawing device, bearing resemblance to the later saw mechanism of Cornelis Cornelisz. However, it remains unclear how far the reading and viewing audience reached at that time. In addition, without people with specific technical knowledge and experience, blueprints of mechanical devices are of limited use. For this reason, the migration of people was the most important factor in the spread of technology in this period.<sup>58</sup>

At the end of the 16th century Holland was an area of outstanding economic development which attracted tens of thousands of people, especially the mass migration from Flanders and Brabant, in present-day Belgium, to the north as a result of warfare, religious persecution and economic adversity caused by the war against Spain. In several fields of society the Flemish and Brabantines were ahead of the Dutch. Their contribution to the economic and cultural prosperity after 1580 was undeniably of the utmost importance. The fact that in this period Holland became a

true nursery of innovation was also due to these immigrants. For example, they gave the first impulse to the development of the Alkmaar – and thus Dutch – industrial windmills. As has been seen, the earliest Alkmaar oil mill was erected on the initiative of the Fleming Lieven Jansz. In 1568 he had fled his home at Moerbeke-Waas with his wife and his brother,<sup>59</sup> when, among other items, he left behind a confiscated wind-driven oil mill, for which his father had received the patent in 1552. In 1572 he appeared for the first time at Alkmaar when he received citizenship. His mill that was erected in 1582 at Alkmaar was an existing mill which he had brought over in parts by ship from his former place of residence.<sup>60</sup>

It is not known whether it was a coincidence or a deliberate choice that brought Lieven Jansz to the windmill-rich town of Alkmaar. More important is the fact that for the distribution of new technologies, two parties are needed: the bearer of knowledge and experience and a receptive environment. If the one does not mesh with the other then further development and dissemination will not take place. What happened at Alkmaar – and later on in the whole of Holland – is that the local people seized the new opportunities after the arrival of the immigrants in order to adapt and improve their own mill technology to the new industrial purposes. The next person who wanted to start a new milling business at Alkmaar, namely a paper mill, was Jan Jacobsz du Bois. It can be assumed from his family name that he too was an immigrant from the south. However, the antecedents of the initiators and followers that came after him are in most cases either unknown or Dutch. Research of the late 16th century Alkmaar citizenship register and marriage notice certificates into relevant indications of profession revealed only two cases of foreign descent.<sup>61</sup>

This last outcome is not conclusive, however. The professions of the initiators and participants who had an interest in mills were various and not always directly linked to the milling industry. Thus a certain Willem Jacobsz Garentwinder became the owner of the second and third paper mills at Alkmaar. However, they often were not real ‘outsiders’ either. According to Van Berkel around 1600, the innovators were predominantly people from outside the business in which the innovation took place. They would not



**Fig. 5.** Cornelis Cornelisz van Uitgeest, the inventor of the wind-driven saw mill, used a crank shaft so that the saw frames perform a reciprocating movement. Paltrock mill *De Gekroonde Poelenburg* at the Zaanse Schans.

have been hampered by a 'traditionalistic mind', as opposed to the established craftsmen.<sup>62</sup> At Alkmaar it is noticeable indeed that initiative and capital could come from various directions, but the registered activities of the people concerned do suggest a structural participation in the milling industry. Thus Lieven Jansz was usually registered at Alkmaar as a grain merchant, although he already possessed an oil mill during his Flemish period. In 1592 Jan Jacobsz du Bois was mentioned as a paper maker as well as an oil miller. In the beginning, the first hemp mill was temporarily owned by people from outside the hemp industry, but one of them was called a paper maker while the other was called a tanbark miller. Maerten Pietersz van der Meyde, the designer of the first Dutch wind-driven fulling mill, was at that time a timber merchant by profession. Before that he had been the Alkmaar town's carpenter and according to his own statement he had been occupied with mills from a very young age.<sup>63</sup>

Carpenters were widespread in this industry. It was this group that brought in the necessary know-how and experience of the craft into the millwrighting business. Many times we see them act as initiators together with a financial investor. Also among the patent applicants, carpenters emerge every now and then. Thus in 1601 the Alkmaar carpenter Ghysbert Arentsz was granted a patent right in Holland for his invention to perform all kinds of processes without the use of wind or horse power. In the same year, his patent request for his wood rasp mill, which he had submitted together with someone from Middelburg, was granted.<sup>64</sup> In 1617, the Alkmaar carpenters IJsbrant Jansz and Claes Cornelisz were granted patent rights for their wind- and horse-driven fulling mill.<sup>65</sup> Leaning on experience with already existing wind-driven drainage mills, a number of Alkmaar carpenters apparently developed themselves into experts in millwrighting and processing equipment. Here too one cannot speak of 'outsiders' that would have escaped from a 'traditionalistic mind'. In addition, the Alkmaar archives reveal almost nothing that points to conservatism within certain branches of industry. Opposition against the new milling technologies does not seem to have occurred at Alkmaar. What is seen, however, is that financial investors of all kinds and conditions collaborate with inventive craftsmen.

Subsequently millers were appointed who worked the mills as paid employees.

When looking at the further development of milling technology after 1580, then it can be seen that ideas from outside were not just imitated by the local people, but were used as a starting-point to extend their own knowledge. Thus from the early days a number of industrial windmills evolved quickly into two specific Dutch mill types: the octagonal smock mill and the paltrok mill. Although the Flemish oil mill of Lieven Jansz was a post mill with open trestle. Cornelis Cornelisz's patent request of 1597 for an edge runner was already based on a multisided smock mill.<sup>66</sup> Also in 1607, the well-known Leeghwater was granted privilege for the first octagonal wind-driven oil mill in Holland.<sup>67</sup> Another development of the Dutch smock mill can be noted from the saw mills. The drawing of the sawing mechanism for which Cornelis Cornelisz was granted patent in 1593 shows a hollow-post mill.<sup>68</sup> The first Alkmaar saw mill from 1595, however, was a smock mill, octagonal in shape. At the beginning of the 17th century, a complete new type of saw mill was developed in the Zaan area. This so-called paltrok mill was a four-sided wooden structure with an extended, open workspace at both sides, placed on top of a circular base on which the whole body was winded by means of an iron roller-ring. As far as the other types of industrial windmills are concerned, there is more uncertainty in this early period. The fulling mill of Van der Meyde is described in the patent as "*so as four-sided as also eight-sided*".<sup>69</sup> But whether this mill at Alkmaar was finally built as a post mill or a cap winder remains unknown, however, his fulling mill at Utrecht in 1596 was octagonal in shape. Of which type of mill the paper and hemp mills were before 1600 is unclear. In the Zaan area, some of the earliest mills were post mills and hollow-post mills.<sup>70</sup> Also on the town plan of Alkmaar made by Drebbel in 1597, other types of mills can be recognised, as well as a few smock mills.

Before Cornelis Cornelisz introduced the edge runner in 1597, vertically placed reciprocating stamps must have been used for crushing the seeds and for squeezing out the oil by means of a wedge press.<sup>71</sup> It was of major importance that the principle of this stamping mechanism could be used in a variety of circumstances for cutting of rags for the paper

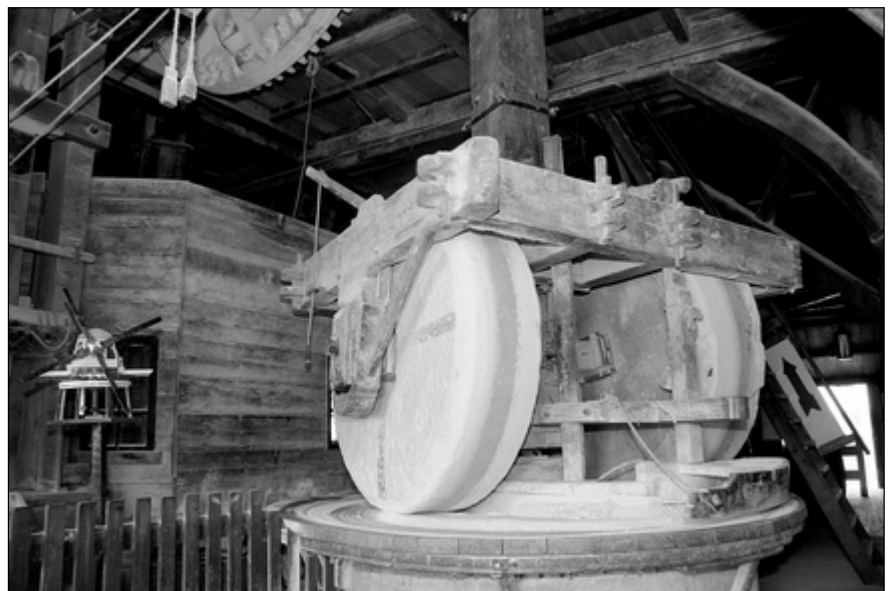

**Fig. 6.** In 1597 Cornelis Cornelisz van Uitgeest received a patent for the edge-runner in his oil mill. In the earliest Dutch oil mills the oleaginous seeds were crushed by stamps. Edge-runner in dyewood mill *De Kat* at the Zaanse Schans.

industry, breaking of hemp and fulling of cloth. Although horizontally or obliquely placed hammers and hole beam could have been used, this does not seem very likely at Alkmaar in this period especially with the oil mill as an example. This is supported by a number of sources, e.g. Voorn, an expert on paper mills, supposes that it is more plausible that the first wind-driven paper mills were not equipped with a hole beam and hammers, but with choppers (i.e. using a stamping mechanism).<sup>72</sup> The patent from 1589 for Albert de Veer states that the milling mechanism “*taps the hemp with stamps thus making them soft*”.<sup>73</sup> According to Goudsblom, around the middle of the 17th century hemp mills were usually equipped with stamps.<sup>74</sup> And in fulling mills, stamps apparently were so self-evident that they were generally indicated as ‘Dutch stamp fulling mills’, as opposed to the ‘German or French hammer fulling mills’.<sup>75</sup> Hence, after the experience with the ‘Flemish’ wind-driven oil and paper mill, it was a relatively small step to the construction of hemp and fulling mills at Alkmaar.

The versatility of the stamp mechanism, except for saw mills, offers a technical explanation for the rapid succession of the different types of industrial windmills at Alkmaar. However, at the same time it underlines the handicraft character of these milling innovations. The innovations did not result from scientific opinions, but from imitation, operating experience and small adaptations and improvements. This explains why even Cornelis Cornelisz, ‘a peasant from Uitgeest’, was able to accomplish a wood sawing device without sufficient understanding of the basic principles of mechanics.<sup>76</sup> Once more it proves that the breakthrough and the rapid development of the industrial windmills at Alkmaar after 1580 had not been possible without its recent milling history. It created artisanal mill experts and innovative entrepreneurs who dared to seize the new possibilities, as soon as economic circumstances were favourable.

### Markets and Mills

Macro-economic theories concerning technical development provide a framework within which innovative processes can take place, but as such do not suffice to

explain time, place and invention satisfactorily. Of all economic incentives for innovation, two usually get full attention: the role of market demand and the shortage of labour. It is claimed that growing economic activity is attended with an increase of inventiveness.<sup>77</sup> It so happened that in the period 1580 – 1620 the economic recovery in Holland was such that it could be described as an explosive growth.<sup>78</sup> The strongly growing demand for goods and the increased trade profits led to considerable more investments in technical innovations than usual. The number of patents that was granted in this period by the States General and the States of Holland grew strongly and around 1620 reached unknown numbers.<sup>79</sup> According to Van Berkel it concerned above all “... *those branches of technology that directly determined the value of a certain product*”.<sup>80</sup> Especially in the textile industry the innovations were directed at qualitative improvements of the finishing. An explanation for this can be found in the internal market demand where, despite a more rapid population growth than elsewhere, the wages increased so explosively that the purchasing-power still grew continuously.<sup>81</sup>

As for the rise of the industrial windmills, the motive was not so much quality improvement of the product, but to replace human labour force. Without mechanisation, the processes that were carried out were burdensome and very labour intensive. The labour costs for sawing, fulling, crushing and stamping by hand were therefore relatively high, especially as wages were increasing considerably. Over all industries, the earnings of the hand sawyers rose the most, until the introduction of the wind-driven saw mills.<sup>82</sup> In addition, the exceptional rise of wages is indicative of shortages on the labour market. Apparently, the supply in certain industries could no longer meet the explosive demand. The shortage of labour as well as the expanding wages will therefore have been a strong stimulus for the introduction of labour saving industrial windmills.

This does not explain, however, why the Dutch industrial windmill started its rise at Alkmaar. Although the above-mentioned developments were taking place in Alkmaar they were equally valid in the whole of Holland. In Alkmaar also, an upward economic movement together with a strong population growth can be seen. In this town there was an identical development of the wages, the hand



**Fig. 7.** Along the Zeglis, on the left is the oil mill *De David*, on the right is the oil mill *De Stroojonker*, and to the right of the latter is the paltrock saw mill *De Kievit*. A few drainage mills are in the distance. Pencil drawing, 1787. Source: Alkmaar Regional Archives.

sawyers being the group where wages rose the quickest with a permanent shortage on the labour market as its most plausible explanation.<sup>83</sup> According to the above-mentioned macro-economic argument, the breakthrough by windmills could have happened elsewhere in Holland as well. For additional economic explanations therefore it is necessary to look for conditions that were valid specifically for Alkmaar. In doing so it should be remembered that the mechanisation with the use of wind power at Alkmaar took place at the beginning of the period of expansive growth. In addition, economic development is not an autonomous process from which technical innovation is directly derived and in which Alkmaar was just automatically taking advantage. Therefore the active contribution that Alkmaar has made in its own economic development has to be taken into account.

Firstly, the economic life in the period 1560 – 1580 will be outlined. Secondly, how Alkmaar subsequently expanded its economic structure further by means of its industrial windmills will be explained in more detail.

### Economic Life, 1560 – 1580

Before the start of the Spanish siege of the town in 1573, Alkmaar was one of the medium-sized towns in Holland. In c.1560 the size of the population can be estimated at around 8,000 inhabitants. The inequality in wellbeing at Alkmaar was relatively small and accumulation of capital remained very limited, especially when compared with the larger towns.<sup>84</sup> From the watery eastern part of town – the Zeglis and the Voormeer – the Alkmaar people had access to the Dutch inland lakes and eventually the open sea. In the opposite direction, the countrymen from the surrounding areas could enter the town with their barges through the canal network.

For centuries the foundation of economic life at Alkmaar was its market function serving a large part of the North Holland countryside. The economic policy of the town council was therefore structurally directed at strengthening it. Eventually, Alkmaar had the largest cheese market in The Netherlands, but also its meat, fish and seeds markets developed rapidly. Because of this regional market function, Alkmaar traditionally possessed a substantial fleet for inland navigation. However, it is remarkable that the

Alkmaar people had only a minor involvement in maritime navigation and hence there was an absence of export industries. In 1561 Alkmaar had, apart from the various small domestic business industries, the disposal of a number of larger companies.<sup>85</sup> This shows that Alkmaar then had an industrial sector of small proportions that predominantly produced low-value goods in small quantities. Apart from small quantities of woollen and linen cloth, it produced primarily raw materials such as salt, lime, oil and products that were needed for all sorts of end processing i.e. leather and rope. A number of these companies would play a role after 1580 in the erection of the new industrial windmills, namely, the oil pressers, the rope makers and the weavers. Big companies with a lot of investment capital, like a large shipyard, were not present. Relatively expensive innovations were therefore hardly to be expected. Over twenty years later and after a successful uprising against Spain, these nevertheless did take place.

The economic damage caused by the siege of Alkmaar and the foraging in the countryside around Alkmaar by Spanish troops and rebels, year after year, was enormous. All industrial buildings that were located outside or near the town walls, like the two tanbark mills and the horse-driven barley peeling mill, were destroyed.<sup>86</sup> In 1573, farmers north of Alkmaar complained amongst other things “... *that their stock of butter and cheese had been largely plundered by the soldiers and that the rest had tainted because of the long storage time resulting from the non-functioning markets*”.<sup>87</sup> Two years later, the town council declared “...*that the town is not as well in business as the other towns of Westvriesland and Waterland, with the consequence that craftsmen such as cobblers and so on do not like to settle in this town owing to a shortage of materials and because of which the town’s commerce and trade declines day after day*”.<sup>88</sup>

The period following the siege, therefore, had to be dominated by rapid reconstruction. Before the introduction of the first industrial windmill at Alkmaar in 1582 the town had refurbished its old, separated industrial structure as much as possible, but it was not sufficient. The circumstances had changed and new opportunities quickly came forward. After around 1580, when the plundering troops and rebels had left, the countryside recovered again fairly quickly. A strong population growth, urbanisation and



**Fig. 8.** Alkmaar was the first industrial windmill town in The Netherlands. View of Alkmaar including a number of mills, c.1700. Source: Alkmaar Regional Archives.

the availability of investment capital were the basis of a renewed and strong revival of the rural economy. If the Alkmaar people wanted to benefit from this, then they had to participate strategically in these favourable developments. The town council provided intensive support and as before tried to strengthen the position of Alkmaar's market in various ways. Also the economic policy extended outside the Alkmaar boundaries. Hoorn, Haarlem and Amsterdam were market competitors of Alkmaar and it was necessary to keep them at a distance. The town council tried to achieve this for instance by obstructing infrastructural improvements between the villages and the other market towns and by optimising its own connections with the surrounding countryside.<sup>89</sup> However, in the struggle for the market attendance, a policy aimed exclusively at market conditions and infrastructure could only be successful if it was combined with an active industrial policy. In order to attract as many market visitors as possible, then a range of home products had to be offered as well. Therefore, Alkmaar did not specialise in one or a limited number of industries, as did industrial towns like Leiden and Haarlem, but instead remained widely orientated. Consequently, not just one, but a number of different types of windmill had the opportunity to prove their usefulness. In the decision to introduce mechanisation using wind power, the strongly increasing labour costs and the shortages in the labour market, no doubt played a role, but the revived entrance into the competition for the market attendant will have been of importance in this period as well.

The extent to which industrial mills were a logical continuation of the existing Alkmaar industrial structure, or a (complete) break with it will be examined. For the answer will provide a deeper understanding of the question as to why Alkmaar became the nursery for industrial windmills in Holland. In addition, it will transpire that Alkmaar industry indeed knew a rich diversity, but that its components were also strongly interrelated.

### **The Economy of Wind Power, 1580 – 1610**

During the beginning of the reconstruction of the Alkmaar economy an new company is emerging in 1575 among the revival of the old industries, this was the soapworks.<sup>90</sup> This company used oil as its main raw material which the Alkmaar oil industry was able to supply. Thus, with his oil mill, Lieven Jansz joined an already existing industry. In addition, the connection with the main raw material of the Alkmaar economy, oleaginous seeds can be noted. Alkmaar developed a seed market that became of major importance, especially in the centuries that followed. The kind of seeds entering the town around 1600 is often not clear, but in market decrees the import of naven and rape is often mentioned.<sup>91</sup> Naven and rape-seed produce rape oil that was used, among other applications, for making soap. In addition, oil was pressed from linseed and hemp-seed, establishing a connection with the Alkmaar linen industry and rope walks. Hemp and flax were grown in the immediate vicinity of Alkmaar. Except for the fibres that were used by the linen weavers the flax produced linseed. The oil pressed from these seeds was suitable for preparing paint and soap. The oil cakes that were left after pressing were extremely suitable as cattle feed for the farmers in the surrounding countryside.

Although paper manufacturing was a totally new kind of industry for Alkmaar, this sector too formed an integrated part of the town's economy. It did not produce white writing paper, but brown packing-paper. For this coarse material, everything the hemp and flax processing industries could supply as waste material was welcome, such as hemp and flax fibres, rope, nets, sail-cloth, thread, and, of course, linen rags of all sorts and colours. Also water was abundantly available, and only a slight purification was required to make brown paper.

A third type of industrial mill that was depending on the hemp industry was, of course, the hemp mill. It is remarkable that the only hemp mill Alkmaar possessed at that time was converted into a fulling mill in 1610, while later on the rope industry assumed a strongly growing importance.<sup>92</sup>

The saw mill from 1595 did not create a new industry either. As a matter of course, a town like Alkmaar needed large quantities of timber, especially for the construction of houses and ships, and for the timber trade with the surrounding countryside. Transporting logs by water was no problem, so lumber mills were to be expected. Simply because of the population growth, there was a necessity to raise productivity, but a shipyard of importance was lacking in the town. It is possible, though, that the wind-driven saw mill had caused some upswing in demand. Immediately after the decision was taken to erect it, plans were made for carpenter's yards at the north bank of the Zeglis and a shipyard was allowed to be established there.<sup>93</sup> Fifteen years later – the second saw mill had meanwhile been built – this area is described as 'ship carpentry yards'.<sup>94</sup> Their size is unknown but presumably these were just a few slipways for inland vessels and barges.

Finally the fulling mills were mainly used for expensive cloths, such as woollen fabric made of short carded wool. The shorter the wool, the more the fabric was covered by protruding fibres, thus the stronger the felting produced by fulling could occur. In the Dutch draper's industry before the war against Spain, the traditional fulling process was an important phase in the finishing. After 1575 the availability of good quality wool was much reduced and the old Dutch drapery with its fullers disappeared quickly from the scene. Before the siege, Alkmaar also had a draper's industry, but compared to that in other draper's towns it was not really of importance.<sup>95</sup> Around 1585 the old draper's industry at Alkmaar had nevertheless somewhat recovered.<sup>96</sup> And in the mid-1590s all kinds of initiatives were taken in order to bring the old Alkmaar draper's industry to full bloom. One of these initiatives was the introduction of a new fulling mill.

In numerous resolutions and in a new draper's charter, the direct interference of the town council with the revival of the draper's industry can be observed. In early 1594 the weavers from outside of the town received free housing and they could use the small church of a former monastery as their working space. The following year it was decided to put into use a fulling mill. In anticipation of this, independent weavers were stimulated to expand their businesses by offering them free rent and financial support for purchasing wool. The town council then wanted to increase the scale of the industry and to achieve that all weavers produced a series of uniform hallmark draperies that met the same quality requirements. For this reason, in 1596, a draper's charter was designed containing business



regulations, descriptions of the Alkmaar hallmark draperies and conditions for their inspection.<sup>97</sup> Four officials appointed by the town council had to execute the inspections and mark the approved draperies with a lead seal. The latter task had to be performed at the 'seal house and draper's hall'. The fulling at the fulling mill was also regulated in the draper's charter, which stated that the fabric had to be 'thickly filled' there. Thus a regulated draper's industry arose with Van der Meyde's fulling mill being an important and new part of it. Production, however, remained very modest.<sup>98</sup> Thus it can be seen that after the uprising and the reconstruction, Alkmaar developed an active policy in order to strengthen its market position during a period of a growing economy. The town, however, was not the only entity stimulating economic politics. In this period all Dutch towns show a strong increase of public support for entrepreneurs starting a business.<sup>99</sup> The only difference is that the Alkmaar people were the first to consider the industrial windmill as an important weapon in the competitive battle between the towns. The town council probably supported this choice because of the weakness of the Alkmaar industry. Without a way to differentiate its home products, the power of attraction of the Alkmaar market was insufficient. The successful example of the Flemish oil mill of Lieven Jansz opened up new possibilities of the use of wind power that matched with the Alkmaar economy. In the first place the need was felt to mechanise labour intensive production processes because of the sharp rise of wages and the shortages on the labour market. Secondly, because of the diversity and the integrated character of Alkmaar's industrial structure, wind power could be applied to a number of purposes. Except for the paper mill, all industrial windmills had connections with industries that had already been active for a long time.

## Conclusion

Why did Alkmaar become the nursery of the Dutch industrial windmills? Taking an overview, economic factors have been observed not to have been decisive. Although the use of wind power within the Alkmaar economy was a logical economical solution, it does not explain as to why Alkmaar was the first to adopt it. The economic situation at Alkmaar did not differ fundamentally from that of the rest of Holland, as it turned out later, the power of wind was a useful source of energy for other towns and villages as well. Considered from an economic perspective, any other town in Holland could have taken the initiative. When compared with other towns, Alkmaar was more or less different because of its favorable location close to the windy coast and because of its broad capability, experience and familiarity with drainage mills. The reclamation of the surrounding lakes required mills with a larger potential power, making a more thorough technical knowledge necessary. At that time, technical improvements did not result from advanced scientific judgment, but from practical experiences and craftsmanship. Thus in Alkmaar and its vicinity, a true experimental environment arose for sympathisers and experts in the field of millwrighting and mill technology, who, more than persons elsewhere, had confidence in windmills as source of power.

## Main Archives

National Archives, The Hague (NAH)

Grafelijkheidsrekeningen [county accounts]; access 3.01.27.02, Vols 160 / 200 / 1018 to 1021 / 1034 / 1037 / 1042 (windmill privilege register; receipts of taxes for the right of wind)

Alkmaar Regional Archives (RAA)

Old-judicial Archives Alkmaar (ORAA), department of Voluntary justice, Vols 132 – 187, Register of real estate property transfer (1580-1810) (deeds of sale)

Alkmaar Notarial Archives before 1842 (NAA), vols 1 – 65  
Alkmaar Town Archives before 1815 (SA),  
Register of town council resolutions, Coll.- Nos 92 to 98;  
Decree books, Coll.-Nos 27 and 31.

SA, Acquisitions Collection, Coll.-Nos 196 and 249

SA, Calendar of town charters, 1254 – 1810

Utrecht Municipal Archives (GAU), town council, arch. 2/121.

## References

1. For this period, Pieter Schotsman has studied systematically the windmill privilege register and the Alkmaar deeds of sale of windmills. These sources have not been specified in more detail in the references. In addition, Herman Kaptein has carried out complementary research in the Alkmaar Regional Archives (RAA), the Alkmaar Town Archives 1254-1815 (SA), and in the literature. He also wrote this article. The old study is: BRUINVIS, C. W., *De Molens van Alkmaar*, 1905.
2. KINGMA, JUR., 'Die grote houten machines', in: DOBBER, WLADIMIR and CEES PAUL, (eds.), *Cornelis Corneliszoon van Uitgeest. Uitvinder aan de basis van de Gouden Eeuw*, Zutphen, 2002, pp.85-124, here pp.88 and 91.
3. GRABANT-PLEGING, J. H. and P. E. M. HARTMAN, 'De Molens aan het Spaarne', pp.91-109, in: SLIGGERS, B. C. (ed.), *De loop van het Spaarne*, Haarlem, 1987; VAN DILLEN, J. G., (ed.), *Bronnen tot de geschiedenis van het bedrijfsleven en het gildewezen van Amsterdam*, Part II, 's-Gravenhage, 1929, No. 615.
4. NIEMEIJER, A. F. J., *Van Accijnsbrief tot Zuidam. Scheepsbouw in Haarlem van 1274 tot heden*, Haarlem, 1990, pp.17-36 and Appendix, Tables I-IV.
5. SA, Acquisitions Collection, Coll.-No. 196: Valuation list of the Tenth Penny of the houses at Alkmaar, 1561, and Town Council Resolutions (Vres.), Coll.-No. 92, *passim*.
6. SA, Acquisition Collection, Coll.-No. 196. This tanbark-mill probably dates from 1543; SA, Calendar of town charters 1254-1810 (Calendar), Coll.-Nos 175 and 302; SA, Coll.-No. 1746; BRUINVIS, pp.28-29.
7. Windmill privilege register, 1595.
8. VAN FOREEST, NANNING, *Kort verhaal van het beleg van Alkmaar. Een ooggetuigenverslag*, Alkmaar Regional Archives, 2000, pp.34-35; supported by: SA, Vres., Coll.-No. 92 fol. 216.
9. SA, Calendar. Coll.-No. 302.

10. SA, Vres., Coll.-No. 93, fol. 182v.
11. VAN DILLEN, *Bronnen*, I, p. 304, No. 513.
12. DENEWET, LIEVEN, 'Lieven Andries uit Moerbeke-Waas: een gevluchte Vlaamse olieslager die in 1568 zijn molenkennis naar Holland bracht', *Molenecho's. Vlaams tijdschrift voor molinologie*, Vol. 27 (4), October-December 1999, pp.185-207.
13. Windmill privilege register, 1595-1597.
14. Resoluties van de Staten van Holland en West-Friesland, 1585.
15. VAN DEN HOEK OSTENDE, H. J., 'Amsterdamse molens', in: COLENBRANDER, BERNARD WILLEM, and R. SCHIMMEL (eds.), *Molens in Noord-Holland: inventarisatie van het Noordhollands molenbezit* Amsterdam, 1981, pp.57-69; ANKUM, L. A., 'Een bijdrage tot de Zaanse olieslagerij', *Tijdschrift voor Geschiedenis*, Vol. 73, 1960, pp.39-57 and 215-251, here pp.46-47.
16. See on paper mills in both provinces: VOORN, H., *De papiermolens in de provincie Noord-Holland*, Haarlem, 1960, and *ibid.*, *De papiermolens in de provincie Zuid-Holland, alsmede in Zeeland, Utrecht, Noord-Brabant, Groningen, Friesland and Drenthe*, Wormerveer, 1973.
17. SA, Vres., Coll.-No. 94, fol. 48 and 51.
18. SA, Vres., Coll.-No. 94, fol. 142 and Coll.-No. 96, fol. 5; Windmill privilege register: 2nd June 1593 and 1614; VOORN, *Papiermolens Noord-Holland*, pp.237-238.
19. DOORMAN, G., *Octrooien voor uitvindingen in de Nederlanden uit de 16<sup>de</sup> tot de 18<sup>de</sup> eeuw*, 's-Gravenhage, 1940, G 8, p.89.
20. HOEK OSTENDE, pp.57-69; GOUDSBLOM, J., 'De hennepkloppers van Krommenie. Een bijdrage tot de kennis van de geschiedenis der zeildoekindustrie', *de Zaende*, 1949, pp.1-22, 57-65, 79-82 and 112-166, here pp.87-88.
21. GOUDSBLOM, p.13.
22. SA, Vres., Coll.-No. 94, fol. 117v-118 and 206v, 208 and 209.
23. SA, Calendar, Coll.-No. 515.
24. Windmill privilege register, 1614.
25. SA, Vres., Coll.-No. 94, fol. 262, 263, 266v, 275v; SA, Vres., Coll.-No. 95, fol. 276v, 233, 39; SA, Coll.-No. 27, fol. 123-126 and 130; Ordonnantie opte draperye, April 1596; Deeds of sale, Notarial archives and Windmill privilege register, 1609.
26. KAPTEIN, HERMAN, *De Hollandse textielnijverheid 1350-1600. Conjunctuur & Continuïteit* Hilversum, 1998, p.165.
27. DOORMAN, *Octrooien*, H 18, p. 281.
28. Resoluties van de Staten van Holland, 16th March 1612, p. 56; BUNSKOEKE, D. M., *Molens van Edam*, Edam, 1999.
29. GAU, town council, arch. 2/121/fol. 133; see also PERKS, W. A. G., *Zes eeuwen molens in Utrecht Utrecht/Antwerp*, 1974, pp.139-140.
30. SA, Vres., Coll.-No. 96, fol. 182-184v.
31. SA, Vres., Coll.-No. 94, fol. 157v-158.
32. SCHOTSMAN, PIETER and LEO DEN ENGELSE, 'De eerste houtzaagmolen van Cornelis Cornelisz. stond aan het Zeglis te Alkmaar', *Molinologie. Tijdschrift voor molenstudie*, Vol. 19, 2003, pp.1-5.
33. DOORMAN, G., *Cornelis Cornelisz van Uitgeest en de Hollandse uitvindingen op het einde van de 16<sup>de</sup> eeuw*, Den Haag, 1952.
34. DOORMAN, *Octrooien*, H 23, p. 283.
35. GROOT, PETER, 'Cornelis Cornelisz van Uitgeest en zijn uitvindingen', in: DOBBER, WLADIMIR et al., pp.11-21, here p.12.
36. SCHOTSMAN and DEN ENGELSE *op. cit.*
37. *Molenecho's. Vlaams tijdschrift voor molinologie*, Vol. 31 (2), April-June 2003, pp.171-181.
38. HUYS, PAUL, 'Oprichting van nieuwe molens in het graafschap Vlaanderen tussen 1574 en 1608', in: *ibid.*, *Molens in veelvoudig perspectief*, pp.195-207.
39. PEKELHARING, W. J., *De Amsterdamsche oliemarkt*, 1918, pp.6-7; PERS, M., *Molens van Friesland*, Leeuwarden, 1971, pp. 8-29.
40. VAN UYTVEN, R., 'The fulling mill: Dynamic of the Revolution in Industrial Attitudes', *Acta Historiae Neerlandica*, Vol. 5, 1971, pp.1-14, here p.11.
41. FORMSMA, W. J. and R. VAN ROYEN, *Diarium van Egbert Alting 1553-1594*, s-Gravenhage, 1964, pp.427-428.
42. DENEWET, LIEVEN, 'Cornelis Corneliszoon is niet dé uitvinder van de houtzaagwindmolen!', *Molinologie. Tijdschrift voor molenstudie*, Vol. 18, 2002, pp.20-24.
43. BASALLA, G., *Geschiedenis van de technologie*, Utrecht, 1993, pp.7-13.
44. Leiden: POSTHUMUS, N. W., (ed.), *Bronnen tot de geschiedenis van de Leidsche textielnijverheid*, 's-Gravenhage, 1910-1922, Vol. III, Nos 134, note 1, 291, 292, 324, sections 66 and 158; Rotterdam: TE LINTUM, C., 'De textielindustrie in oud-Rotterdam', *Rotterdamsch Jaarboekje*, Vol. VIII, 1900, p.23; Haarlem: KAPTEIN, H., *Textielnijverheid*, p.165; GROENMAN, S. J., *De Haarlemse industrie der zware lakenen van 1573 tot 1671*, unpublished essay, 1936, p.2.
45. See the study of many years' duration by the KNMI [Royal Dutch Meteorological Institute] into wind velocities in The Netherlands for the period 1971-2000, at <http://www.knmi.nl/onderzk/index-nl.html>.
46. BICKER CAARTEN, A., *Middeleeuwse watermolens in Hollands polderland 1407/08-rondom 1500*, Wormerveer, 1990, pp.44-56.
47. STREEFKERK, C., 'Duizend en een dijkgraven', in: POP-JANSEN, M. L. and C. STREEFKERK (eds), *Duizend en een dijkgraven. 800 Jaar waterbeheer in Alkmaar* Historische vereniging Oud-Alkmaar, 1994, pp.15-34, here pp.25-26.
48. BICKER CAARTEN, pp.227-229.
49. SCHOORL, H., 'De bedijking van de Bergermeer', *Alkmaars Jaarboekje*, 1970, p.75.
50. SA, Coll.-No. 196. For the 'Viaan' see <http://home.wanadoo.nl/~amv/>.
51. SIPMAN, A., *Molenbouw. Het Staande Werk van de Boven Kruiers*, Zutphen, 1990, pp.98-99.
52. BASSALA, pp.7-9, 41, 80-82.
53. KELLENBENZ, HERMANN, 'Technology in the Age of the Scientific Revolution 1500-1700', in: CIPOLLA, CARLO M., (ed.), *The Fontana Economic History of Europe. The Sixteenth and Seventeenth Centuries*, Glasgow, 1974, p.178; VAN PROOIJE, L. A., 'Verspreiding van houtzaagmolens in de tijd van de Republiek', in:

- Vierhonderd jaar houtzagen met wind: verslag van de studiebijeenkomst 'Een besonder creckwerck' ter gelegenheid van de vierhonderdste verjaardag van het octrooi van Cornelis Corneliszoon van Uitgeest gehouden 27/28 november 1993 te Woudsend, Sprang-Capelle, 1996, p.34.*
54. BERNET KEMBERS, A. J., *Oliemolens*, Arnhem, 1962, pp.64-65.
  55. *Ibidem*, pp.53-55.
  56. DAVIDS, C.A., 'De technische ontwikkeling in de vroegmoderne tijd. Literatuur, problemen en hypothesen', *Jaarboek voor de geschiedenis van bedrijf en techniek*, Vol. 8, 1991, pp.9-138, here pp.18-21.
  57. KELLENBENZ, p. 82.
  58. CIPOLLA, CARLO M., *Before the Industrial Revolution*, Cambridge, 1980, pp.185-192.
  59. DENEWET.
  60. SA, Not. H.J. van der Lijn/Alkmaar, 30 April 1610 / 37/ fol. 167v.
  61. Migration project-C. LESGER, University of Amsterdam; with thanks to Clé Lesger for making the data available.
  62. VAN BERKEL, K., 'Enige opmerkingen over de aard van de technische innovatie in de Republiek omstreeks 1600', *Tijdschrift voor de geschiedenis der geneeskunde, wiskunde, natuurkunde en techniek*, Vol. 3, 1980, pp.123-144, here pp.141-143.
  63. PERKS, *Utrecht*, p.139.
  64. DOORMAN, *Octrooien*, G 52 and G 63.
  65. *Ibidem*, G 154.
  66. SA, Vres., Coll.-No. 95, fol. 110-110v, 122v and 129.
  67. Windmill privilege register Graft-De Rijk; LEEGHWATER, J.A., *Een Kleyne Chronycke ende voorbereydinge van de Afkomst ende 't vergrooten van de dorpen van Graft en de Ryp*, Amsterdam, 1724, pp.10-11.
  68. DOORMAN, *Cornelis Cornelisz*, Plate 2 and p.4.
  69. DOORMAN, *Octrooien*, H 18, p.281.
  70. KINGMA, pp.99-102.
  71. The quoted Flemish register of 1574-1608 exclusively mentions oil mills equipped with stamps for the area where Lieven Jansz originated; HUYS, pp 196-199. The first Alkmaar oil mill equipped with edge runners dates from 1602; SA, Vres., Coll.-No. 95, fol. 231-231v. In addition see especially BERNET KEMBERS, pp.69-70.
  72. VOORN, *Papiermolens Noord-Holland*, pp.31-37.
  73. DOORMAN, *Octrooien*, G 8.
  74. GOUDSBLOM, p.2.
  75. VAN GORP, P. J. M., 'Over vollen en volmolens: een industriële revolutie in de vroege middeleeuwen', *Brabants Heem*, 1979, Vol. 2, pp.66-128 and Vol. 4, pp.142-160, here p.121; see also POSTHUMUS, N. W., *De geschiedenis van de Leidsche lakenindustrie*, 3 volumes, 's-Gravenhage, 1908-1939, Vol. II, p.247, and *ibid.*, note 5.
  76. VAN BERKEL, p.128; DOORMAN, *Cornelis Cornelisz*.
  77. BASALLA, pp.135 and further.
  78. DE VRIES, JAN and AD VAN DER WOUDE, *Nederland 1500-1815. De eerste ronde van moderne economische groei*, Amsterdam, 1995, especially pp.768-771.
  79. *Ibidem*, p.408, graphics 8.11.
  80. VAN BERKEL, p.142.
  81. NOORDEGRAAF, L., *Hollands welvaren? Levensstandaard in Holland 1450-1650*, Bergen, 1985, especially pp.93-94 and 170-172.
  82. DE VRIES and VAN DER WOUDE, p.771.
  83. NOORDEGRAAF, L., *Daglonen in Alkmaar 1500-1850*, 1980, especially pp.44-58, 69-71 and 84-86.
  84. VAN DEN BERG, W. J. and J. L. VAN ZANDEN, 'Vier eeuwen welstandsongelijkheid in Alkmaar, ca. 1530-1930', *Tijdschrift voor sociale geschiedenis*, Vol. 19, 1993, No. 2, pp.193-215; for the population: pp.200-202 and Table 2; for the unequal level of prosperity: especially pp.205-206 and Table 6; for the population sizes of the other towns in Holland in 1570: ISRAEL, J., *The Dutch Republic. Its Rise, Greatness, and Fall 1477-1806*, Oxford, 1995, p.328, Table 12.
  85. SA, Acquisitions Collection, Coll.-No. 196.
  86. SA, Calendar, Coll.-No. 318.
  87. VAN NIEROP, H., *Het verraad van het Noorderkwartier. Oorlog, terreur en recht in de Nederlandse Opstand*, Amsterdam, 1999, pp.159-160.
  88. WORTEL, TH. P. H., 'Een merkwaardige kaart van Alkmaar en omstreken', in: *Alkmaars Jaarboekje*, 1970, pp.93-95.
  89. ATEN, DIEDERIK, 'Als het geweld comt ...'. *Politiek en economie in Holland benoorden het IJ 1500-1800*, Hilversum, 1995, especially pp.37-49.
  90. SA, Vres., Coll.-No. 92, fol. 237v, 279v and 300, Coll.-No. 93, fol. 39 and Coll.-No. 96, fol. 195.
  91. SA, Coll.-No. 27, fol. 147; Decree books c.1575-1613, Coll.-No. 28, fol. 2.
  92. VAN DER WOUDE, *Noorderkwartier*, Table 5.16, p. 331.
  93. SA, Vres., Coll.-No. 94, fol. 265v and 270v.
  94. SA, Vres., Coll.-No. 96, fol. 50-51v and 239v.
  95. NOORDEGRAAF, L., 'Textielnijverheid in Alkmaar 1500-1850', in: *Alkmaarse silhouetten, Alkmaarse Historische Reeks*, Vol. V, Zutphen, 1982, pp.39-64.
  96. SA, Coll.-No. 27, fol. 52; Vres., Coll.-No. 92, fol. 216v and 249v.
  97. SA, Coll.-No. 27, fol. 123-126 and 130.
  98. SA, Coll.-No. 1952.
  99. DAVIDS, C. A., 'Beginning entrepreneurs and municipal governments in Holland at the time of the Dutch Republic', in: LESGER, C. & L. NOORDEGRAAF (eds), *Entrepreneurs and entrepreneurship in early modern times. Merchants and industrialists within the orbit of the Dutch staple market*, Den Haag, 1995, pp.167-184, especially pp.167-170.
- Note:** this paper is a condensed version of the original article (in Dutch) which was published in: J. DREWES ET AL. (ed.), *Alkmaar, stad en regio. Alkmaar en omgeving in de Late Middeleeuwen en de Vroegmoderne tijd*, Alkmaarse historische reeks XII, Hilversum, Verloren, 2004, pp.183-226.
- In 2007 the article was awarded the I. J. de Kramer Publication Prize by TIMS Netherlands and Flanders, presented at the 12th TIMS Symposium at Putten, The Netherlands.

Int Molinology 2010,80:26-34

## Sugar Mills (Tawahin es-Sukkar) in the Jordan Valley

Ruba Abu-dalo

### Introduction

The Jordan Rift Valley is a unique region with specific characteristics. It lies entirely below sea level and is known as the lowest location on the earth's surface. It has long been recognized that the Jordan Valley represents one of the richest and most promising archaeological regions in the Middle East.



Fig. 1. Map of the Eastern Mediterranean showing the location of Jordan.

Sugar cane was one of the most important crops in the eastern Mediterranean basin in the Ayyubid and Mamluk periods (12th-15th century). Sugar cane was introduced into the Jordan Valley in the late 11th century as part of what is known as the Islamic agricultural revolution. Its cultivation and the technology involved in the manufacture of cane sugar soon spread across many sites of the area between the Yarmouk River in the north and the Dead Sea in the south.

This study aims to investigate the sugar mills in the Ghour area during the Islamic periods in general, with particular emphasis on the period between the 12th-14th centuries including the presentation of the results that have been obtained through field work carried out by the author at several of the most relevant sites. The contemporary sugar producing technology, which has been documented and studied across a range of archaeological work carried out by the various expeditions in the region, is addressed. In addition, technical illustrations have been prepared based on

the results of archaeological excavations and historical studies.

This time period was chosen because it was shown in the historical sources to be crucial in the history of sugar cultivation and manufacturing in the Ghour area. At this time Sultans paid great attention to sugar manufacture as a means of reviving the economy. These activities contributed immensely to the political, economic, and social aspects in the area during that period.

Although limited archeological evidence related to sugar manufacture has been uncovered, the archeological research which has been conducted recently at many sites in the Ghour proved that several of these sites were sugar manufacturing areas. When this archeological evidence was considered in relation to the historical information, it became clear that this specific period was particularly remarkable in this concern.

### The History of Archaeological Research

Focusing entirely on the Ghour area in the Jordan Valley between the Dead Sea and the Yarmouk River, the archaeological sources for this area come from many surveys and excavations performed in a series of studies.

These began in 1887 when Schumacher presented a study concerning several archaeological sites which he had visited, including Tabaqat Fahil (Pella) (Schumacher, 1889: p.31-36). He mentioned two sugar mills in Pella and also three other mills in Wadi Zeglab, Wadi Waguss, and Wadi Arab. (Schumacher, 1889: p.149-160).

Between 1938 and 1947, Glueck conducted a large survey in the Jordan Valley in which he mentioned many mills (Glueck, 1951: p.235-318).

In 1981, Rami Khouri stated in his book on the Jordan Valley that in 1975/6:

“The most systematic survey of the valley floor, between the Dead Sea and the Yarmouk River, was conducted by the Jordanian Department of Antiquities, the University of Jordan and the American Center of Oriental Research (ACOR) in Amman”

This study was led by the participants Moawiyah M. Ibrahim, Khair Yassine and James Sauer, representing the three institutions respectively. The result of these surface explorations led to the identification of 224 sites based on the occupational history of the Jordan Valley since Palaeolithic times (c.200,000 – 17,000 BCE) until the present. These sites were listed according to their history of occupation, state of preservation, and their potential for future excavations.

Following this survey, a series of excavations were conducted at Tell Ash-Shunah North, Tabaqat Fahil (Pella), Tell Al-Hayyat, Tell Abu An-Ni’aj, Tell As-Sa’diyyeh, Tell Al-Mazar, Tell Deir ‘Alla, Tell Al-Handaquq, Tell Al-Himmeh, Tell Damiyah, Tell Ash-Shuna South, Al-Kharrar (Baptism site) Tell Al-Iktanu, and Tuleilat Ghassul. Immediately after the survey, Henk Franken and later

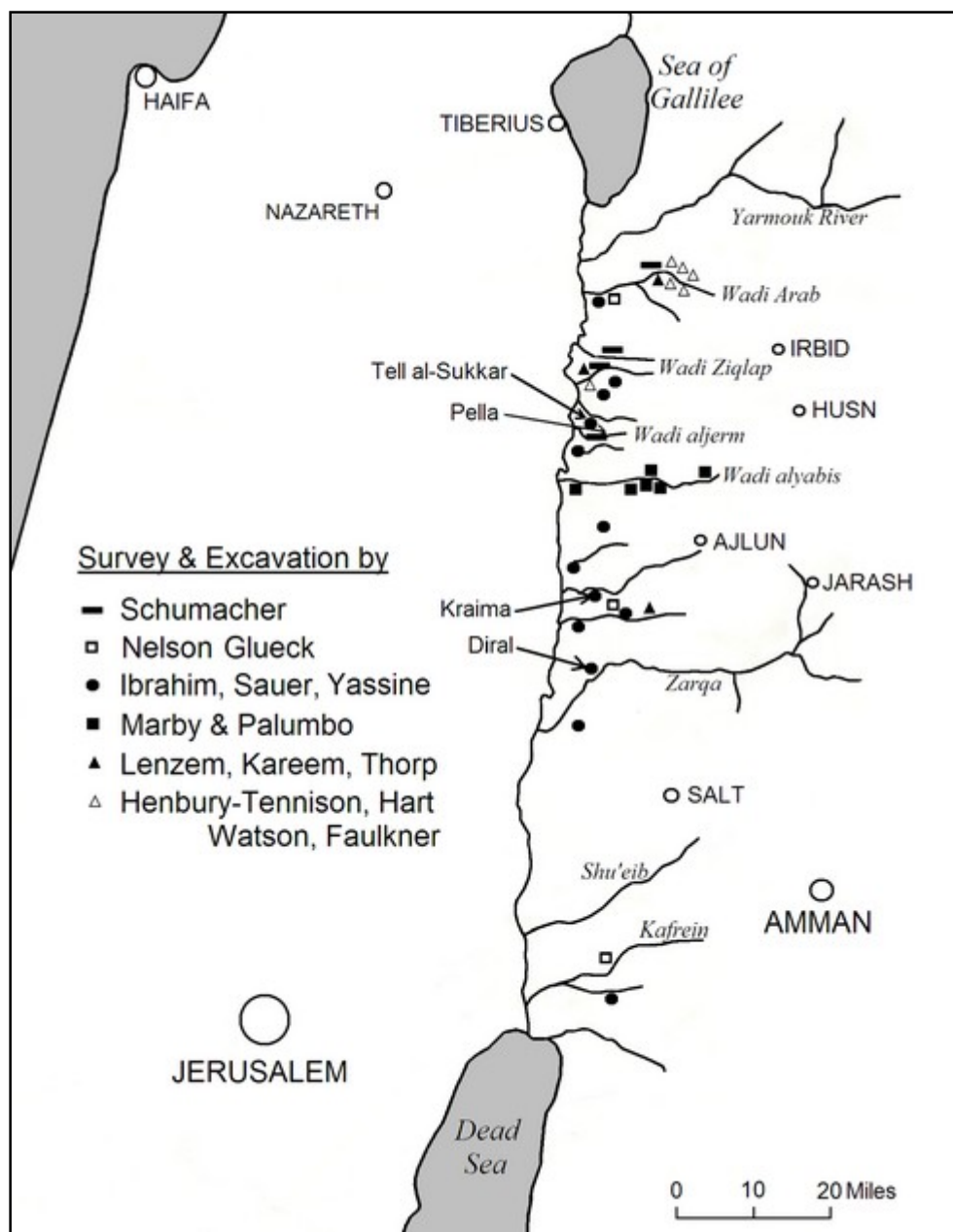

Fig. 2. Map of the Jordan rift valley showing the locations of various archaeological surveys and excavations.

Gerrit van der Kooij (1976-1994) teamed up with the others to excavate Tell Deir Alla in the central Jordan Valley.

The preliminary results of the survey and the excavations were published in *BASOR* 222, *ADAJ* 22; 23; 26; 38 and in other journals and books (Ibrahim; Sauer; Yassine 1976: p.63-65; 1988: p.182-185). In this survey the archaeological remains of 13 sites of sugar mills along the Jordan Valley were identified. These sites are Tell aS-Sukar, Rasiya, Tell Abu al-Bessa, Kherbet Miraqeah, Kherbet Slehat, Krayma, Tell Abu el-Qos, Dhirar, Zmaliyye, Ardha, Sapeera, Tell et-Tahuneh, Mesalhe. In addition, a lot of sugar pottery sherds were found which had been used in the manufacture of sugar in the following sites: Der-ala, Tell-qadan, Tell-et-Tahuneh,

Abu-Ubayda, and Tell-Shooneh Alshamali which were all dated from the 12th-14th century.

In 1983, Hanbury-Tenison; Hart; Watson; and Falkner conducted a survey in Wadi Arab. This survey resulted in the discovery of six mills dating back to the Ottoman period (1515-1918) without mentioning the function of the mills (Hanbury-Tenison, et al. 1984: p.385-424).

A survey in Jesser Shekh Hussein, which took place in 1986, by Lenzen, Thorp and Kareem resulted in the finding of six sites related to sugar mills dating back to the Ayyubid Period (1173-1260). (Kareem, 1987: p.75-77; p.453-455).

Finally, in 1987, another survey conducted jointly by the Arizona University and Rome University discovered a large number of sugar mills in Wadi Yabbes. (Marby and Palumbo, 1989: p.296-299).

### Archaeological Excavations

Following these surveys there were several excavations at some of the sites which gave very good information about sugar manufacturing. However, these excavations did not focus on the architectural remains of sugar mills but their main concern was to find sherds of sugar making pottery. Sherds of this type were found in Tabqet Fahil Pella (Smith, 1973: p.230; Walmsley, 1989:p.440), Tell Abu Taqan (Franken and Kalsbeek, 1975: p.1-12, p.236-245), and Tell Abu Sarboot (de Hass et al., 1989: p.323-326; LaGro, 1990: personal communication).

Based on these surveys and excavations, it seems that many archeological remains connected to this industry have been found in the Jordan Valley. This type of industry, which manufactures sugar of high quality for commercial use required a great deal of manpower for the cultivation of sugar cane and for manning the production of sugar in the mill. Also a large capital investment was needed to establish a sugar mill and to build up a distribution network for trading the product overseas, where it was sold for a high price. These conditions, coupled with the requisite political situation and sufficient financial support, are the reasons why the sugar industry could emerge and further maintain itself during the 12th - 14th century.

### Historical sources

It was obvious that the archeological surveys and excavations did not focus on the information provided by the historical sources. References in historical sources describe the area in question as farmland possessing all the elements of agricultural production namely, the fertility of the land, the availability of water, and the ideal

growing weather conditions. For this reason, the area known as the Jordan Valley, has had agricultural stability since ancient times, which is clearly confirmed by archaeological discoveries at various sites in the Jordan Valley.

Agricultural activity has played an important role in shaping the lives of the societies that lived in the area throughout the historical period. However, the importance of agricultural activity and its impact on the composition of the structure of social and economic characteristics may, in some cases, be related to or dependent upon other types of economic activities in order to grow and flourish and become a distinct activity in that geographic area. Perhaps these other activities associated with farming activity, plus the dependences on water for both sugar cane cultivation and for providing power for the sugar mills could explain why the sugar industry is always located in the area where the sugar cane is cultivated.

### Technology of the Sugar Industry

Historical sources dating back to the 9th century onwards indicate the presence of many agricultural crops such as sugar cane, without mentioning it directly, thereby making it difficult to determine the quantity of sugar mills present or the location of their remains.

A detailed explanation on the cultivation and processing of sugar cane was given by Ahmad ibn Abd alWahhab Nuwayri in his book *Nihayat al'Arab fi Funun Aladab (The Aim of the Intelligent in the Art of Letters)*, one of the best known encyclopedias in Mamluk Egypt, published in 1332, and he also provides a detailed explanation on the various aspects of this industry in Egypt and Syria, as follows:-

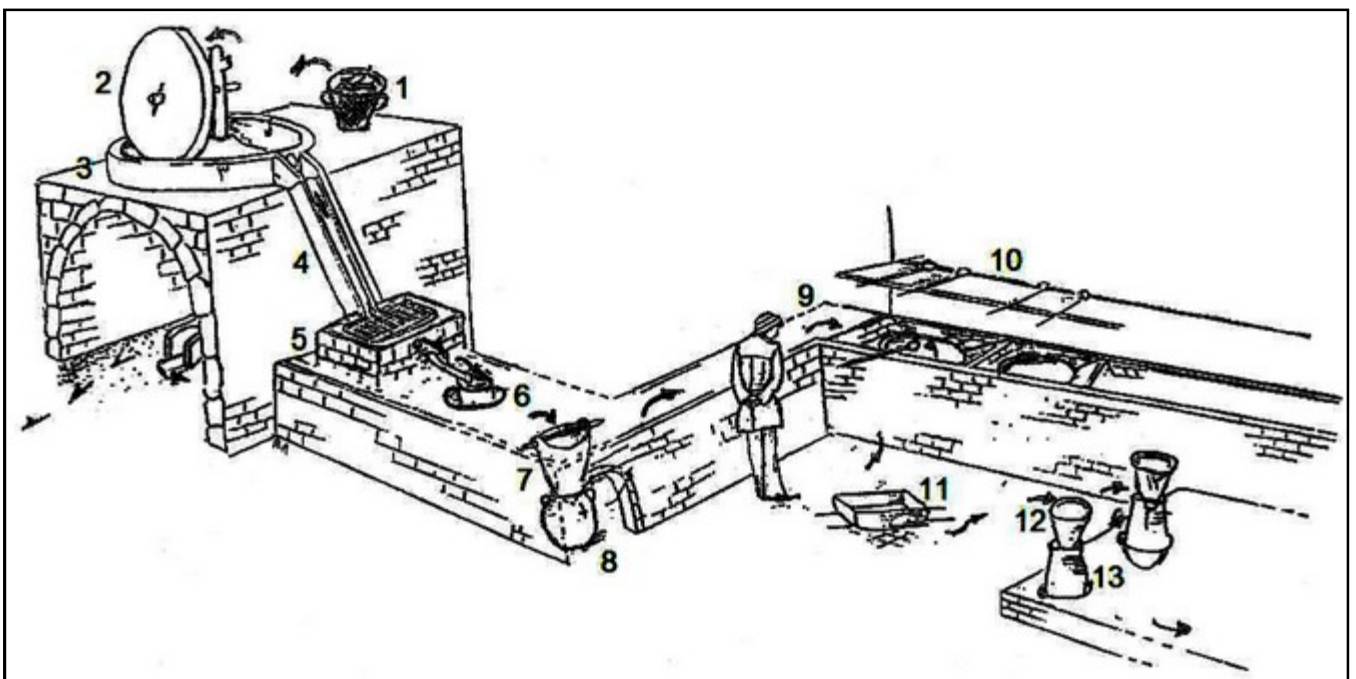

Fig. 3. The sugar production process as described by Nuwayri.

1. Aleyarat or Alafrad. 2. Stones. 3. Altakht. 4. Drainer. 5. Albahoo. 6. Jars (Kabiya).
7. Alyaqatin. 8. Big Dinan. 9. Dezoot. 10. Kodoor. 11. Alkraneeb. 12. Alabaleej. 13. Alqawadees.

“The process of producing sugar involves several stages, where the sugar cane was carried on camels or donkeys from the fields to the factory composed of many rooms usually indicating the plant’s facilities. The main steps in the production of sugar are: (1) The canes are gathered and cut in lengths of half a palm after cleaning, (2) crushing the sugar cane in the press to extract the juice, (3) boiling the juice in copper boilers to give a syrup, (4) when thickened, this syrup is collected in baskets made of slender twigs, and lastly (5) the sugar becomes dry and hard.

The cut canes are placed below the millstone which is turned by good oxen, and through that the juice is squeezed out. When the canes are pressed out as much as possible, they are transferred to another place. The pulp is packed into baskets made of rushes with slits on the sides and at the bottom. These baskets are then put under the wheel which is moved by beams, until the pulp is completely crushed and the last juice has run out of it”

He further elaborates:-

“The boiled juice is poured into moulds of earthenware, which are narrow below and wide above. In the bottoms are holes, which are plugged with pieces of sugar cane for the first phase of the evaporation process. These moulds are placed on top of other vessels, into which, in an advanced stage, flows the syrup which is separated in fine drops, while after some time the crystalline sugar, formed like a loaf or cone, can be removed from the moulds.” (Nuwayri, 1976: p.267-275)

It was necessary to carry out a field work project at Tell aS-Sukar, Kerima, Fahl, and Dhirar in order to bring into focus the technical aspects related to the subject. The fieldwork included testing some sites that were deemed necessary, for example at Fahl. Other sites such as Tell aS-Sukar and Kerima were only documented by photography and architectural recording.

The results derived from the archaeological surveys and excavations in the Jordan Valley are insufficient for complete understanding, consequently the historical sources must be studied. Many aspects of the contemporary world are still

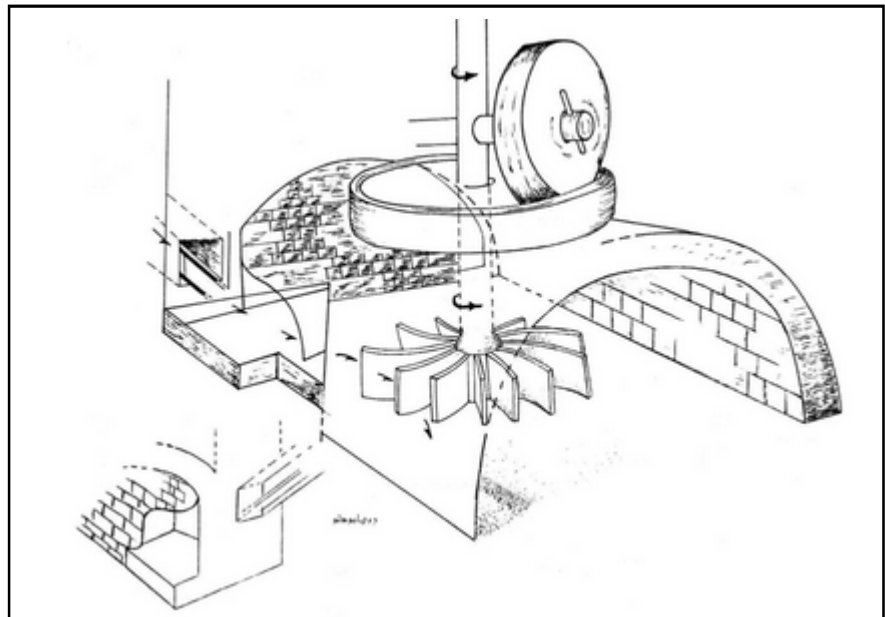

**Fig. 4.** Reconstruction of the sugar mill at Tell aS-Sukkar in the Ghour area built during the Islamic Period.

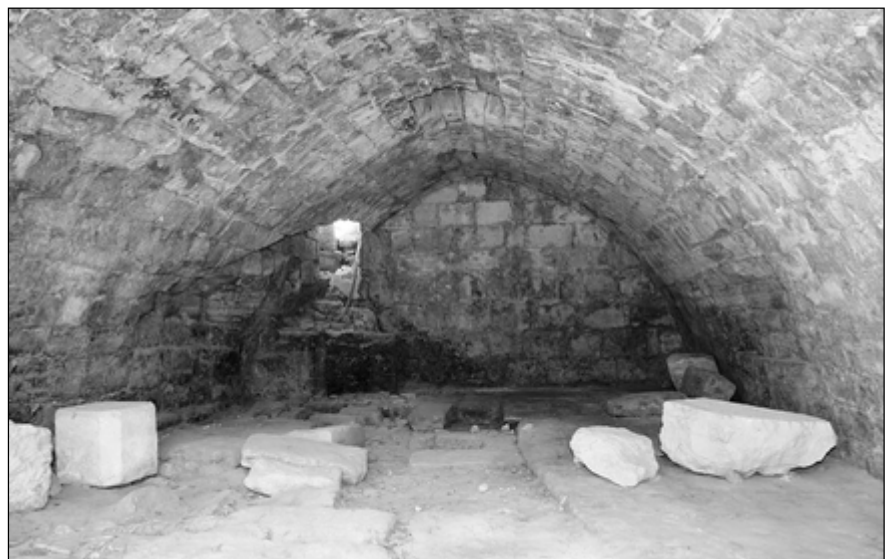

**Fig. 5.** A wheel chamber similar to the one that exists at Tell aS-Sukkar.



**Fig. 6.** The remains of the arch on which stood the sugar mill platform at Tell aS-Sukkar.

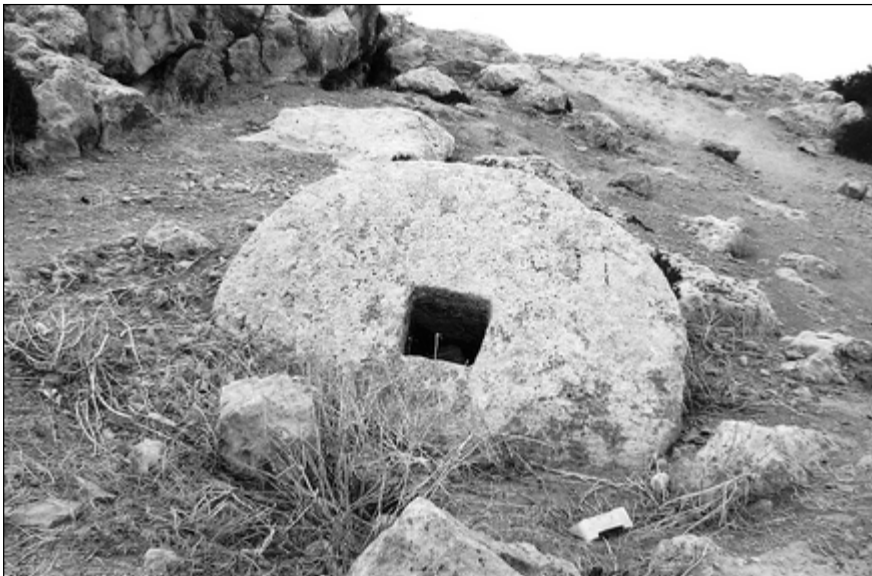
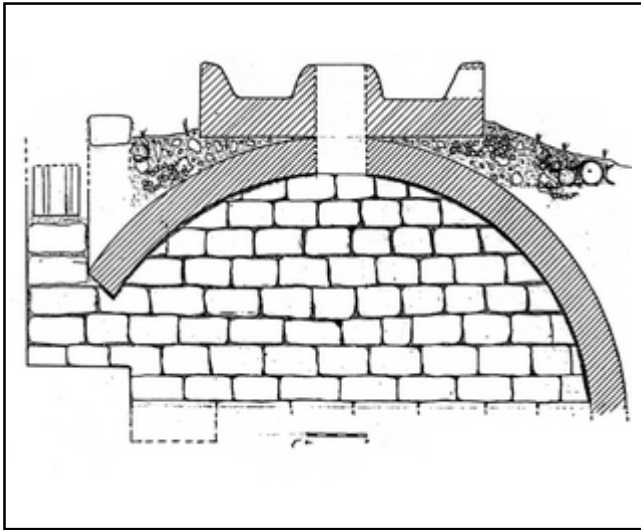

**Fig. 7.** The edge runner stone at Tell aS-Sukkar showing the square hole in the centre.

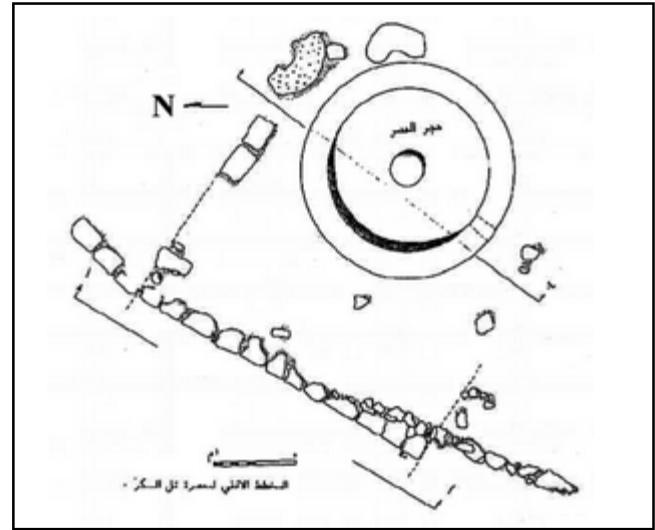

**Fig. 8.** The base stone at Tell aS-Sukkar showing the circular channel in which ran the edge runner.





**Fig. 9.** A cross sectional drawing of the sugar mill platform at Tell aS-Sukkar.



**Fig. 10.** A plan of the sugar mill at Tell aS-Sukkar, showing its directional orientation.

unknown and unclear but by using these sources then a better understanding of the sugar mills in the area can be achieved.

The most important sites included in the visits and field work was Tell aS-Sukkar (see Fig. 4 - 10). This site includes two sugar mills, the first in the north and the second to the north-east.

This sugar mill was supplied with water from Pella, which was brought along a conduit. In places, the water ran on an aqueduct supported on a 2 m high, arched, stone wall. At the heart of the main part of the sugar mill was a circular base stone with a circular trough. This had a hole in its side to run off the liquid, and another in the centre through which a shaft came to drive an edge runner stone. The water channel was found inside the building in the eastern corner where there was evidence of the passage of water. Also a lot of pottery sherds were found that came from sugar pots.

#### Analysis of the Quantity of Sugar Mills

Through the architectural remains that have been studied in both the Tell aS-Sukkar, Tell Dhirar

(see Fig. 11-13) and Krayma (see Fig. 14), and also by consulting the available historical sources and recent archaeological discoveries, it has been concluded that the remains of the sugar mills were built on the sides of the rivers or alongside streams because sugar cane, being an irrigated crop, relied on an exploitable water supply. This could also provide the water power to operate the sugar mills. Along the Jordan Valley 34 sites (map Fig. 2) have been identified so far, although this is not an accurate number for there may be more sites not yet known to us. The number of sites found of the sugar mills found depends on the results of previous archaeological surveys. There are many reasons that determine this number, including:-

1. There are many sites mentioned that include more than one sugar mill, without specifying the quantity of sugar mills available.
2. There are many sites mentioned that have a lot of sherds of sugar pots without the presence of architectural sugar mill remains.
3. Rebuilding some of the remaining sugar mills for other uses such as grinding grain.

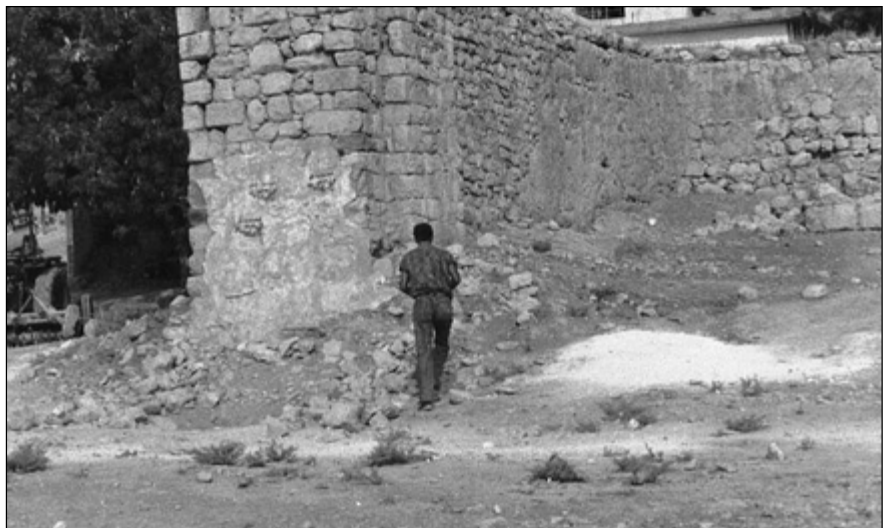

**Fig. 11.** The remains of the drop tower at Dhirar. The person is standing where the sugar mill used to be located.

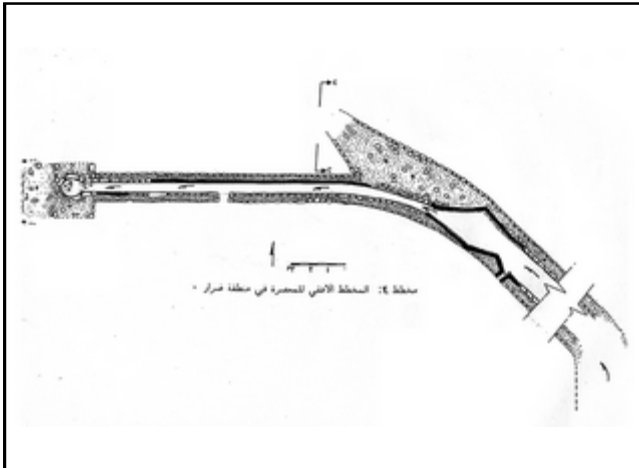

**Fig. 12.** Plan of the leat to the Dhirar sugar mill. The top of the drop tower is at the left.

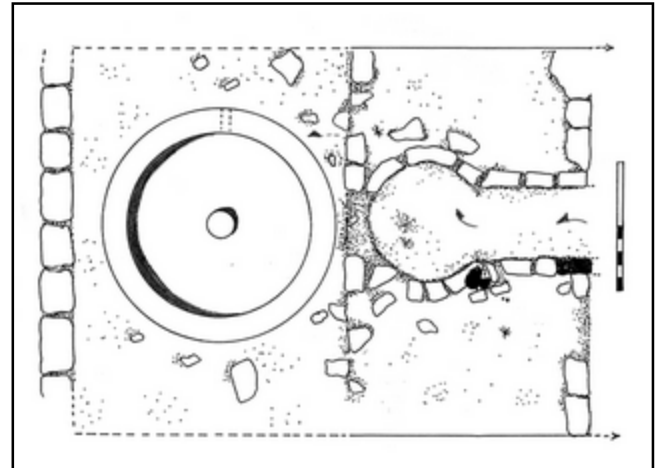

**Fig. 13.** Plan of the remains of the edge runner platform at Dhirar sugar mill.

### The Waterwheels and Millstone

All these mills in the Jordan Valley used the same system for crushing the sugar cane, namely a vertical edge runner mounted on a horizontal stone base with a circular channel in which the edge runner ran.

However, two very different methods were used to provide the motive power to the edge runner. The first system used an animal, such as a donkey or oxen to directly move the edge runner. The second method used a horizontal waterwheel to provide the necessary power. The remains of this second type of crushing system were discovered at Tell aS-Sukar.

Although sources indicate that the basic design of horizontal waterwheels had been common throughout the Mediterranean area since as early as the first century BCE, the water supply system used to drive these horizontal waterwheels in the Jordan Valley was quite sophisticated.

Water was taken from the nearest flow of water at a point some distance away from the mill and at a height above the mill. It was then transferred to the mill in a water

channel. This water channel maintained its height by following a contour in the landscape. Where this was not possible the channel would be built on top of a stone arched wall to form an aqueduct over lower lying ground. On arrival at the mill there were two possible delivery systems.

If the water supply was plentiful it could be directed down an open chute onto the paddles of the horizontal waterwheel. Alternatively, if the water supply was limited maximum power could be extracted from it by using a drop tower. In this case the water was delivered to the mills by way of an aqueduct that ran high above the wheel. At the end of the aqueduct the water travelled down a vertical pipe to a small spout at the bottom of the pipe. The combination of the pressure built up by the vertical distance traveled and the small size of the opening at the bottom created a powerful water jet. This jet generated sufficient power to turn the horizontal waterwheel which was housed in a stone vaulted room directly underneath the edge runner crusher. The waterwheel was linked through a hole in the roof of the waterwheel vault to drive the edge runner located above.



**Fig. 14.** The remains of the aqueduct carrying the leat to the sugar mill at Krayma

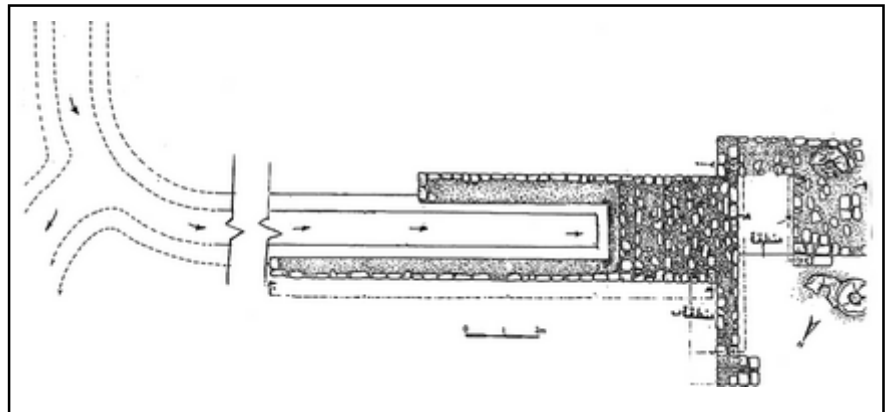

**Fig. 15.** Plan of the aqueduct to a sugar mill at Pella. Here the water runs down a steep angled channel rather than vertically down a drop tower.

The stones for both the edge runner and the base were circular and were quarried out of basalt rock. The base stones were as described at Tell aS-Sukar above, and the millstones had a square hole in their centres where a wooden axle would have been fitted. The millstone was kept turning in the channel of the base stone by the waterwheel and sugar cane, cut to suitable lengths, was placed under the turning edge-runner stone resulting in the extraction of sugar cane juice. The sugar cane juice was boiled in copper kettles and then poured into the cone shaped moulds to allow the sugar to crystallize and to drain the remaining juice (molasses).

### The Cone-shaped Mould, or Sugar Pot

Throughout the survey and archaeological studies previously mentioned, a large number of pieces of pottery associated with the sugar industry were found that were identical to the ones in other sites that had undergone archaeological excavations or surveys. This pottery was found, either in complete form or as sherds. These pots have no decoration on them. Some of the pots that were found were very fragile and vulnerable and can easily shatter. There are also other pots that are more stable in nature which were broken in getting out the sugar cones.

It has been possible to identify two kinds of sugar pots. The first one being cone-shaped with the circular part being in the range of 30-44 cm in diameter, and narrow at the bottom with a round hole in the base having a diameter of 5 cm and walls 1 - 4 cm thick. The potter has most likely thrown them on a rotating wheel but sometimes they have used their hands to put pressure on the walls of the vessel as evidenced by the presence of finger marks on the surface.

The second type has the form of a vase without handles being 25-35 cm in height, the body narrows toward the bottom and has an increasing diameter with thickened walls, ranging between 2-3 cm thick. The base is flat with a diameter between 8-10 cm, the neck being straight with a diameter between 10-14 cm wide.

This confirms the previous surveys and archaeological excavations which mentioned the use of sugar pots and their various shapes and forms as used in the sugar manufacturing industry. Also the research supports the references in historical sources. Perhaps the first mention of sugar making was by Nuwayri in 1332 who specified that two types of pottery were used in the final stages of the manufacturing process, namely:-

- *Alabaleej*: also known as “Bell shape” pottery, being wide at the top and narrow at the bottom, having three punctured holes in the base. It varies in size and capacity. The function of the alabaleej is to drain the molasses, so that only sugar is left inside.
- *Alqawadees*: also known as “Bag shape”, is pottery used to collect the dripping molasses. The molasses dripped through from the alabaleej pottery which sits on top of the alqawadees pottery. The sugar left in the top pot (alabaleej) becomes solid and takes the shape of its container which is in the form of a cone. The alqawadees has two functions:

The first is to support the conical vessel (the bell shape) during the dripping process, allowing the sugar in this upper vessel to crystallize.

The second is to collect the molasses during the dripping process. This process can be repeated a number of times as required. This type of pottery is also used for many other purposes other than for the manufacture of sugar, such as the collecting the water or the storage of grain.

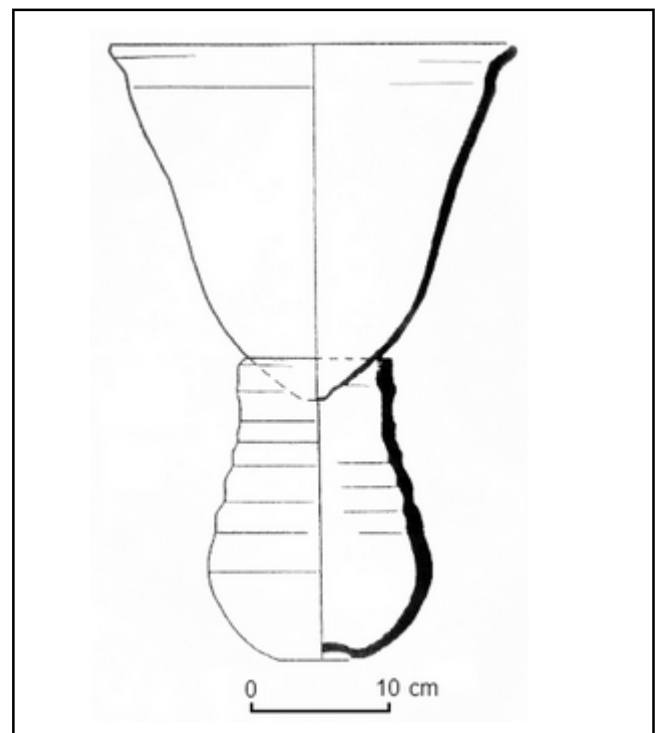

**Fig. 16.** A sugar pot and its associated molasses pot.



**Fig. 17.** A variety of sugar pots and their associated molasses pots

Nuwayri provided us with extra information on the various tools that were used in the sugar industry in addition to the above-mentioned pottery, including:-

- *Jars (Kabiya)*: clay pots of different sizes, which are used as containers to collect the extracted cane juice.
- *Aldeenan*: the smaller pots used for when the molasses was drained for the third time to complete the process. Knives: made of specific plants like palm frond or bamboo. The leaves of the palm were used to make baskets for the sugar canes.
- *Alafrad*: a vessel made of bamboo, which is the term commonly used among the people of Egypt.
- *Albahoo*: a basin where cane juice is collected. This is the container that receives the juice when it first pours out from under the crushing stones.
- *Alyaqatin*: a large gourd in a spherical shape, or sometimes an ovoid structure that grows very large when it matures. The outside layer of this fruit is used as a container for the cane juice. Lots of wool is placed inside the container. The wool works as an absorbent material. Its purpose in the process is to remove impurities from the cane juice
- *Dezoot*: a kettle made of copper, mostly without a neck, sometimes with handles, which is used to boil the cane juice after being extracted.
- *Alkraneeb*: a large scoop used to take the boiling sugar juice from the kettle and pour it into the pottery vessels.

## Conclusion

The results of this study indicate that the period and area under investigation are extremely important for sugar cultivation and sugar manufacture. Furthermore, it should be noted that a large-scale archeological project is essential in order to elucidate the various aspects related to sugar manufacturing at these sites.

## Bibliography

1. NUWAYRI, AHMAD IBN ABD ALWAHABLWAHAB, *Nihayat al'Arab fi Funun Aladab, (The Aim of the Intelligent in the Art of Letters)*, Egypt, 1332. Reprinted in 1976. (in Arabic)

2. FRANKEN, H. J. & K. J. KALSBECK, *Potters of Medieval Village in the Jordan Valley*, North Holland Publishing Co., Amsterdam, 1975.
3. FRANKEN, H. J., "Tell Abu-Ghurdan", *AKKADICA*, VIII, 1989, pp.99-100 edited by HOMES-FREDERICQ, D. and J. B. HENNESSY, Peeters: Belgium.
4. GARDINER, M. & A. MCQUITTY, "A Water Mill in Wadi El Arab, North Jordan and Water Mill Development", *PEQ*, 1987, p.24-32.
5. GLUECK, N., *Exploration in Eastern Palestine*, New Haven, CT., U.S.A., 1951.
6. HANBURY-TENSION, J., "Wadi Arab Survey". *ADAJ*, XXVIII, 1984, p.324-385.
7. HENNESSY, J., T. POTTS, A. MCNICOLL, & A. WALMSLEY, "Preliminary Report on the Fourth Season of Excavation at Pella in Jordan 1980". *ADAJ*, XXXV, 1981, p.267-307.
8. HENNESSY, J., A. MCNICOLL, J. HANBURY-TENSION, P. WATSON, L. RANDLE. & A. WALMSLEY, "Preliminary Report on the Fourth Season of Excavation at Pella", *ADAJ*, XXVII, p.325-361.
9. HENNESSY, J. B., P. C. EDWARD, A. WALMSLEY, S. BOURKE, & J. TIDMARSH, "Pella", *AKKADICA*, 1989, pp.409-442 edited by HOMES, D., AND F. & J. B. HENNESSY, Peeters, Belgium.
10. IBRAHIM, W., J. SAUER, and K. YASSINE, "The East Jordan Valley Survey, 1975", *BASOR*, 222, 1977, pp.41-66. Also "The East Jordan Valley Survey, 1976", *Archaeology of Jordan: Essays and Reports*, 1988, pp.189-207 edited by YASSINE KHAIR. Amman.
11. KAREEM, J., *Evidence of the Umayyad Occupation in the Jordan Valley as seen as in Jiser Sheikh Hussein Region*. Unpublished M. A. Thesis, Institute of Archaeology and Anthropology, Yarmouk University, Irbid, Jordan, 1987.
12. KHOURI, R., *The Jordan Valley Rift and Society below Sea Level*, Longmanns, New York, 1981.
13. LAGRO, H. E., "Abu-Sarbut", *AKKADICA*, VII, 1989, pp.118-120, edited by D. HOMES, D. and F. & J. B. HENNESSY, Peeters, Belgium.
14. LENZEN, C. J., J. KAREEM, and S. THORP, "The Jisr Sheikh Hussein Project, 1986", *ADAJ*, XXXI, 1987, pp.313-320.
15. MARBY, J. and G. PALUMBO, "The 1987 Wadi el-Yabis Survey", *ADAJ*, XXXII, 1988, pp.275-305.
16. ABUDALO, A. RUBA, *Sugar Manufacturing in the Ghour Area, Tell aS-Sukar during the Islamic periods in general with particular emphasis on the period between the 12th - 14th centuries A. D.*, M.A. Thesis (in Arabic).
17. ABUDALO, A. RUBA, "Sugar Production Installations in the Jordan Valley", in *Modesty and Patience, Archaeological Studies and Memories in Honour of Nabil Qadi (Abu Salim)*, edited by HANS GEORG K GEBEL, ZEIDAN KAFABI AND OMAR AL-GHUL, 2009 (in Arabic).
18. SCHUMACHER, G., *Pella*, London: R. Bentley and Son, 1889.
19. SMITH, R. H., *Pella of the Decapolis 1: The 1967 Season of the College of Wooster Expedition to Pella*, The College of Wooster, Ohio, 1973.
20. WALMSLEY, A., "The Mamluk and Early Ottoman Period", *AKKADICA*, VIII, 1989, pp.440-441, edited by D. HOMES, and J. B. HENNESSY, Peeters, Belgium.

Int Molinology 2010,80:35-42

## The Donixmühle in Oberseifersdorf, Germany

Erik Tijman

### Introduction

In the south-east of the German state of Saxony is the region of Oberlausitz. This region's south-eastern part is an area with a number of outstanding windmills. Although this mountainous region, reaching heights of almost 800m (Lausche, 793m), would appear to be better suited to watermills, due to the small number of streams this is not the case. Watermills have been built there, but only on a limited scale. On the other hand windmills were strongly represented in the area, being present at over twenty-five locations. In this area, which is where the three countries of Germany, Czech Republic and Poland meet, post mills were dominant although there were a few tower mills as well. The mills, with their characteristic appearance, stood on the hilltops and were visible from great distances. With their respective miller's houses - usually a characteristic "Umgebindehaus" typical of the region - they formed an unmistakable element in the Oberlausitz landscape.

Most of the post mills were renovated during the 19th century as the millers strove to meet the requirements of that period, and to make it possible to take advantage as new machinery became available. Some mills were altered several times, every alteration changing their appearance. Today there remain nine post mills, although the one at Neundorf has been replaced by a completely new mill, which does not have the same appearance as its historical predecessor. The other eight post mills are in a more or less complete condition, although the Zimmermannmühle at Leutersdorf and the Hetzemühle at Hetzwalde are missing their sails. These two mills both have a sail cross that carried five sails.

### The History of Donixmühle

The Donixmühle in Oberseifersdorf is also missing its four sails as well as its wind shaft. The mill belongs to a 'Dreiseitenhof', so-called as it is a farm with three sides, which is located on a hill in the landscape on the east side of the road from Löbau to Zittau. The mill is on the south side of the yard and from it there is a panoramic view over the surrounding Oberlausitz mountains, the town of Zittau, and the Czech and Polish countries. The house - an "Umgebindehaus" - is at the northern end of the eastern wing of the court. Also on the northern end, but in the west wing, there is an electrically driven mill with a roller mill and a pair of grinding stones. This mill was built in the years 1934/1935. Both buildings are connected to each other at their northern ends by a large barn. At the house on the east side a stable is being built and there is an orchard to the south of the windmill.

The mill was built in 1789 as a post mill by miller Gottlieb Prasse. At that time it had a short skirt so the trestle was clearly visible. The corner posts were - typically for this region - extended almost to ground level and were called "Sturmständer" (during storm they could be fixed with wedges). The mill had a normal width, (by east German notions) of about 4.80 metres.

The first conversion probably took place in the beginning of the 20th century, when the wainscoting was extended downwards until close to the ground, so that the trestle was concealed and free from the influence of the weather. A new floor was made within the room thus created. In a way typical of the region it was implemented as follows. The cross trees of the mills in this region are mortised together so that they lie in the same level. This



**Fig. 1.** The mill court. On the left is the electric mill; on the right the "Umgebindehaus".

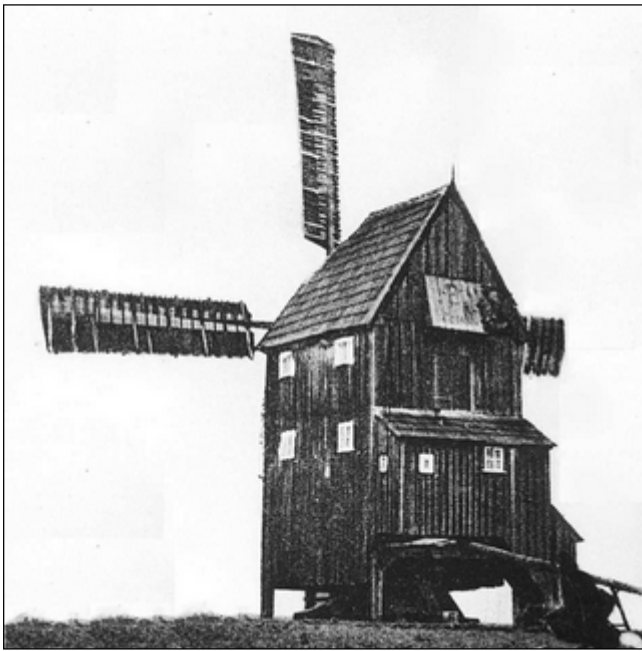

Fig. 2. The Donixmühle with its long corner posts.



Fig. 3. The converted mill in the beginning of the 20th century. At the rear is a door to get on the first floor.

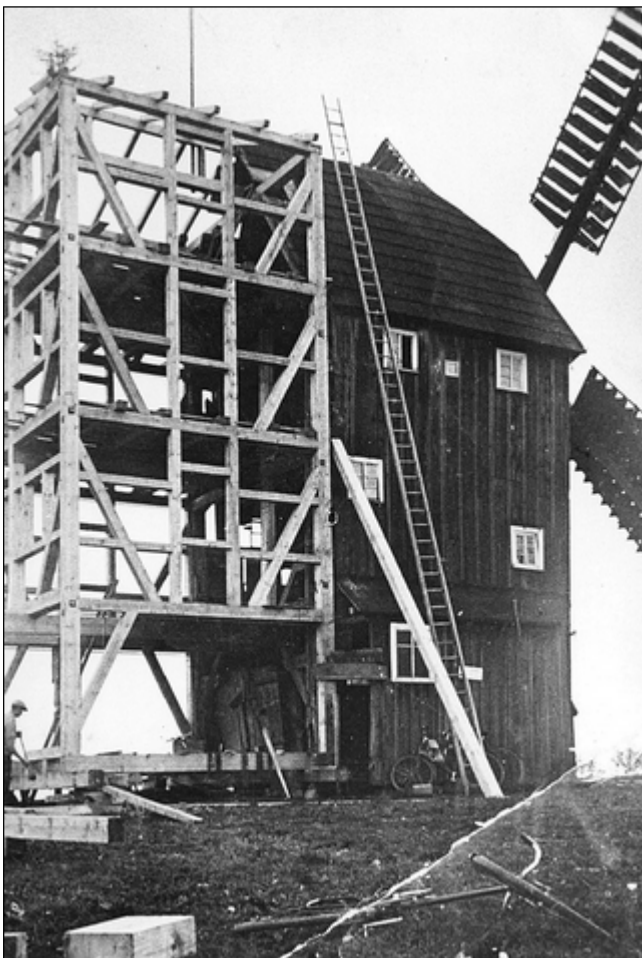

Fig. 4. The second conversion in the year 1937.



Fig. 5. The Donixmühle at the end of World War II. Notice the 'Umgebendehaus' in the background.



**Fig. 6.** One of the large wheels under the extended mill running on the iron rail on top of the concrete circle.

made it possible to create a circular floor reaching to the ends of the cross trees. Bars, sufficient to bear the floor, were fitted between the ends of the cross trees and were partly supported on the ground. At this new level, a floor was made attached to the mill body with a circular hole which was closely aligned with the circular floor within the cross trees. This provided a useful new floor, with the proviso that part was fixed and the other part swivelled with the mill when it was turned. This type of floor structure still exists in all the remaining Oberlausitzer post mills and is also to be found in Poland. The mill also received lateral extensions at the cross tree level, which gave the mill the appearance of a German 'Paltrockmühle', as was the case for several mills in this region. At this height the mill had a reasonable width and made an imposing impression. Also since the tail side of the mill was expanded, meaning that the pannier was enlarged such that it stretched from the cap down to ground level so that the floor space could be significantly increased. In 1913, an electric motor was installed and it could be that the transformation of the mill took place at that time. The motor was seldom used during its first 22 years.

The space created was used for the storage of grain and tools and also offered the possibility of a wind-driven goods lift (Fahrkunst), serving beside the old sack hoist. Most millers used it also as a personel lift. In subsequent years the mill was regularly altered when improvements in the milling process took place. When there was no room in the mill the only option was to make an external addition to the mill. A roller mill made by MIAG was placed alongside the existing millstones.

In 1937 the miller decided on a further extensive conversion, which means that the mill can be described as unique. The extension at the rear of the mill and the stairs were removed, but the special two-part floor was maintained. A new, complete timber-framed mill body was built against the rear of the existing mill. This was a little bit wider than the original mill.

The new building also received lateral extensions on the first storey, however these were broader than the extensions on the old mill. The total width of the mill was now nearly 8 metres. The new cap was a rather flat roof, which provided additional attic space. The transition between the old roof and the new one was constructed with sloping surfaces to obtain a good wind conduction. Because the trestle construction would not be able to bear the weight of the whole building, the mill was supported by two heavy, slightly conical iron wheels, which were located radially below the new building at an angle of about 60° from each other. The wheels ran on an iron, flat rail which was installed on top of a concrete ring. It is not clear whether this rail described a full circle or only a part of one. There is a possibility that it made only a limited winding angle because of the huge mill building.

Much of the existing mill was maintained in use, while in the new housing a complete new facility with modern machines was installed. Also several silos were constructed. New machines included a plansifter, grain cleaner, aspirator, metal silos, elevators, corn crusher, etc.. The stairs, which gave access to the interior, were replaced by a loading platform with a door in the middle and a small staircase which faced to the right.

The company did not stand still. Although in a separate barn a mechanical mill layout had been realized some years earlier, the windmill was maintained and repaired. But eventually the time came when the wind was no longer used. The windshaft and sails were removed after World War II, when the mill was electrified. At the height of the sail cross a new floor level was installed where machines were placed. The opportunity arose to fix the mill body in a western direction and to provide the ground floor with large stone walls. The lateral wooden extensions were removed at the same time. The windmill era of the Donixmühle was definitely over, but when the milling company ceased production is not known. The Mühlenhof was used up to the 1970s as a farm, after which this activity was gradually reduced until the entire area was left to its fate.

### The Current Situation

The complex is currently as described above. The complete installation of the mill is in a reasonable state, although some parts require replacement. The house which is typical of its type and a valued survivor needs a lot of restoration (The Umgebendehaus is an endangered type). The electric mill is in a somewhat better state. The entire site with its buildings deserves to be preserved and repaired. The first step has been taken as a family from the nearby village of Olbersdorf has been attracted by the fate of the complex. They recognised the cultural-historical value of the whole site and purchased the land and buildings in 2007. In recent years they have spent around 2400 hours cleaning and providing much needed repairs, such as waterproofing and burglar proofing. They now bubble with plans to restore the whole site. The house and stables can be converted into a holiday home or bed and breakfast accommodation, the mills may be restored and a museum of rural life established. The brick walls around the mill will be demolished and the mill will again be made windable and then be provided with cross shaft and sails, returning the mill to the state it was during the 1940s.

### However .....

The purchase of the complex was an expensive investment. It was hoped and expected that money would be easily available from grants but unfortunately that appears in practice to be not so simple. Contacts have already been established with professors of the Hochschule Zittau to get help, which has yielded positive responses. But there will still be a lot of money needed. The mill is truly unique and deserves the attention of every one, and will eventually be an tourist and molinological attraction of the first order

So I ask the readers of International Molinology to take notice of this Mühlenhof and if possible to visit. A first step could be to visit the website:

<http://www.muehlenhof-oberseifersdorf.de/>

**Contact:** Mühlenhof Oberseifersdorf, Löbauer Str. 1,  
D-02763 Oberseifersdorf, Germany  
**Telephone:** 0174 / 9 103 435  
**E-mail:** [info@muehlenhof-oberseifersdorf.de](mailto:info@muehlenhof-oberseifersdorf.de)

Figures 2, 3, 4 & 5 are from Deutsche Fotothek:

website: <http://www.deutschefotothek.de/>

Figures 1 & 6 are by the author, taken in June 2009.

---

### Leonardo's Mill for Milan

In 1506 the French governor of Milan was planning the construction of a summer villa outside the city. Leonardo da Vinci, angling for a well remunerated job as the governor's engineer, proposed the following version of an air conditioning fan to make life more bearable in the heat of the Italian summer. In his book *Leonardo da Vinci: Flights of the Mind*, 2004, pp.405/6, Charles Nicholl introduces the master's own words by commenting "The pièce de résistance was a little mill powered by water but with sails like a windmill."

"With this mill I will generate a breeze at any time during the summer, and I will make water spring up fresh and bubbling... The mill will serve to create conduits of water through the house, and fountains in various places, and there will be a certain pathway where the water will leap up from below whenever someone walks there, and so this will be a good spot for anyone who wants to spray water

over women....With the mill I will create continuous music from various instruments, which will sound for as long as the mill continues to turn."

This is a series of ingenious devices for pumping and using water, rather than a mill as we understand the term. Musical automata, trick vessels and water-raising machines fascinated the Renaissance mind just as they had the Hellenistic philosophers and scientists of Alexandria 1500 years earlier: men like Hero, who described a wind organ worked by an *anemourion*, a kind of horizontal windmill powering the piston that provided the air for organ pipes.

Note that Leonardo expected the governor to have a chauvinistic sense of humour, to be indulged in water-based practical jokes so beloved by Renaissance princes.

Michael Harverson

---

### Welcome to New Members

Helen Beneki, Athens, Greece

Rick Osborn, Suffolk, England

AMS/CYPRO, Nicosia, Cyprus

Ola Sjöström, Harlösa, Sweden

Dimitrios Chelmiss, Athens, Greece

Konstantinos Toumpakaris, Athens, Greece

Anastasia Margie, Rhodes, Greece



## Jerusalem's Montefiore Mill to be Restored

In IM57 (December 1998) Michael Dufau first drew attention in this journal to "The First Windmill of Jerusalem", built in 1857 at the expense of Sir Moses Montefiore by the British millwrights J. J. & T. R. Holman of Canterbury. In an article from *The Illustrated London News* of 18th December, 1858, a detailed account had been given of the erection of the mill, and illustrated with a magnificent drawing, which both were reproduced in IM. Two modern postcards of this mill, showing the tower mill with fake cap and sails in the 1990s, were subsequently published in IM58 (July 1999), provided by Mr. C. A. van Hees.

Born in Italy, Sir Moses Montefiore (1784-1885) later moved to London where he was one of the most famous British Jews of the 19th century. He was a banker by profession, and became one of the twelve "Jewish brokers" in the City of London. He was a brother-in-law of Nathan Rothschild, a member of another famous banking family. He retired from business in 1824. A few years later, in 1827, he visited the Holy Land for the first time, after which he became a strictly observant Jew. Six more times he would visit the Holy Land, the last time at the age of 91. In order to help the poor of Jerusalem, the philanthropist Montefiore donated large sums of money to promote industry, education and health. Apart from the windmill that bears his name, he built a printing press and a textile factory, and helped to finance several agricultural colonies. These activities were part of a broader program to enable the Jews of Palestine to become self-supporting in anticipation of the establishment of a Jewish homeland.

The windmill, standing at Yemin Moshe (right hand of Moses), the first Jewish neighbourhood built outside the Old City walls, worked for almost twenty years providing cheap flour to poor Jews. It had been built according to contemporary British design, equipped with fantail and patent sails and working two pairs of stones, grain cleaner and flour dresser. The battered tower is about 15 metres high.

In 1948 the upper part of the mill was severely damaged when the British tried to blow up the mill because the Hagana, the Jewish resistance movement, used it as a lookout tower in their defence of Jerusalem. Since then the tower carries a fixed dummy cap and sails.

After some years of preparations and research, the Dutch "Christians for Israel Trust" have now launched their initiative to restore Montefiore's Windmill to full working order. In collaboration with the owner of the mill, the Jerusalem Foundation (founded by the legendary Jerusalem mayor, Teddy Kollek), plans have been made not only to restore the mill, but also to give it a new future. After restoration it will be part of a new museum about the history of the return of the European Jews to their homeland, Israel. The restoration of the windmill itself will be carried out in two phases. The first phase includes the installation of a new rotating cap with windshaft and brakewheel, and mounting new sails and a fantail, while the second phase will concentrate on the gearing and the milling machinery.



An undated old photograph of a derelict Montefiore's Mill, probably taken in the 1940s.

Mr Gerrit Keunen, former mill expert at the Dutch National Service of Listed Buildings, has agreed to act as technical adviser. Meanwhile, the restoration plans have been approved by the city of Jerusalem. The work can actually start now. It is expected that Montefiore's Mill, a landmark regarded as a "sign of hope" by the citizens of Jerusalem, will be able to grind again in a few years time, 150 years after its erection.

I am grateful to Mr C.A. van Hees who provided me with a copy of the brochure on the restoration of Montefiore's Mill.

Leo van der Drift

## References

- Brochure "Hope for Jerusalem" by the Christians for Israel Trust
- Wikipedia, page on Moses Montefiore

### Hart Park Waterwheel, Bakersfield, California

Hart Park is located along the Kern River in northeast Bakersfield, California. The park is situated below the Panorama Bluffs along several bends in the Kern River. There are several amenities in the park for local residents, but even those visiting from out of the area may find Hart Park a relaxing locale to cool off and escape the summer heat.

After nearly eighty years, the Wheel House in Hart Park still stands (just about), and remains attractive to picnickers, hikers, photo hobbyist, and abandoned cats. At the moment a chain link and wood fence surrounds the perimeter of the Wheel House to keep the public out and away from the structure and makes the location safe for visitors (i.e. inaccessible).

The structure of the Wheel House continues to decay, as has been the case for many years. El-Nino, with its associate heavy rains, accelerates this decay. The recent rain has caused more collapse, especially the upper outside quarter of the wheel and the east entrance to the generator house.

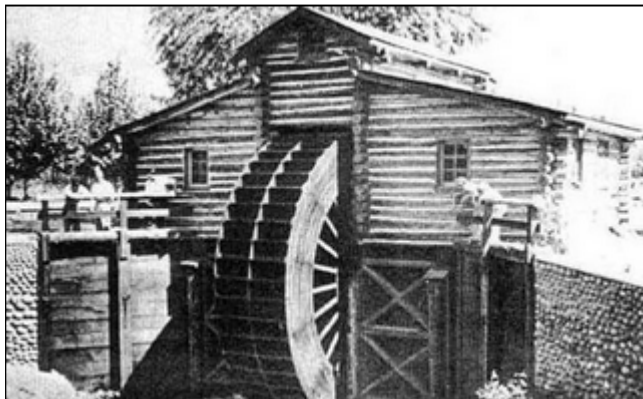

**Fig. 1.** Hart Park waterwheel used to provide electric lighting to the park in the 1930s.



**Fig. 2.** Hart Park waterwheel today, partly collapsed and surrounded by a safety fence.

The waterwheel was built in the early 1930s to supply limited hydro-wheel electricity to the park before the dam at nearby Isabella was built in the 1950s. After the dam was built, the wheels useful life as a reliable source of electricity ended.

The ideas heard from various people in the community to “restore” the waterwheel have nothing actionable attached to their ideas. Without anything actionable, the water wheel will certainly disappear, perhaps after the next El-Nino. However, the waterwheel will never be restored to its former practical glory as there is no water to drive it.

Efforts are underway to raise funds to create a Waterwheel Play Area, something for everyone to enjoy, especially children. This effort would transform the waterwheel into a centre piece of a world class playground. The waterwheel would be fully surveyed and then demolished allowing a “look alike” waterwheel to be constructed as a centre piece of a children’s play area.

### Water Power in Indonesia

Very little is known regarding the use of waterpower in Indonesia. In this former Dutch colony, many tea and other plantations, managed by Dutch entrepreneurs existed up till the Second World War.

In her novel “Heren van de thee” (Lords of the Tea) published in 1992, the author Mrs. Hella S. Haase, who is well-known in The Netherlands, describes life on some of these plantations in the Preanger region of the island of Java in the 19th century. The novel is heavily based upon extensive correspondence of several members of the Kerkhoven family, who ran a number of tea plantations in this region. Because of these references, the suggestions in the novel should be taken seriously.

In the novel, two references were made regarding the use of water power on the Gamboeg and neighbouring plantations:

A water wheel. In 1883, a water wheel was used to drive a “mill”, used to shell coffee berries, produced on the plantation (likely into beans and waste). The water wheel was designed and made by the manager/owner (who was

educated as a civil engineer at the famous Technical University in Delft, The Netherlands). He used “Rasamalawood” (botanical species: *Altinga excelsa* Nor.) for the wheel. The wheel originally was designed to drive a circular saw in the workshop where tea boxes were built (to ship the tea). Details about the type of wheel or of the intermediate drives are not given. It is mentioned that the “mill” could easily be overfed when too much coffee was poured into it. This suggests a limited power source.

A turbine. In 1906, a turbine was constructed which was driven by the Tjisonday creek that ran through the plantation. It was used to drive a generator to supply the plantation and its surroundings with electricity. Again, no technical details are given. Only the plantation owner, Mr Robert Kerkhoven, exclaims that his installation is the best of the Preanger region, better than the neighbouring Ardjasari plantation and that at the same time, a much larger station was being constructed in the town of Bandoeng.

## Trompas Catalanas

Postscript to "Watermills in the north-west of Spain"

In my paper "Watermills in the north-west of Spain" to the TIMS 2000 symposium I referred to the interesting blowing system found in some of the hammer mills in Asturias and Leon Provinces. At the time I had not been able to find the pressure generated for the air blast. I have now been able to return and take a measurement. I also need to correct an error in my diagram of the system – the falling water actually lands on a slab above general water level, and the subsequent splashing assists the separation of the air and water. The corrected diagram is shown below.

These rare examples of hydraulic compressors are known locally as Trompas Catalanas. The name suggests that they originated from the Catalonia, but in a meeting at Barcelona in 2004, museum experts were only able to show the skeletal remains of one example there, insufficient to appreciate how it worked. They seemed unaware of the working examples further west. I have since learnt there is also another at the copper smithy at Navafria in Segovia District, north of Madrid.

The diagram is a corrected version of the sketch I made for the original paper; water is fed in by the operator pulling a cord hanging close to the hearth, which operates a lever to lift a simple plug valve. The water drops down a tube about 200 mm square, sucking in air via a venturi arrangement through holes in the tube walls near the top. The air/water mix gathers momentum and falls out at the bottom onto a stone slab within a large vessel, where the air and water separate, having gained some pressure in the process. The water falls to the bottom of the vessel and overflows via a u-tube, which enables the air to be trapped and fed out through a pipe at high level and led directly to the hearth.

The air flow generated was very smooth and blew the forge most effectively. I had long been curious as to the pressure it could generate, and recently made a return visit to the forge at Santa Eulalia de Oscos. Using a simple manometer I was able to measure the air pressure by operating the blower while the forge was cold. The forge was then lit and it heated up very quickly, so that professional blacksmith Friedrich Bramsteidl who operated it could get back to work with little delay.

I found that, with a water depth in the headrace of 1.2m, a fall in the pipe of nearly 3 metres, and a receiver at the bottom 0.6m deep a pressure of 130mm of water was generated (1.2 kpa, or 0.18 psi.). I was quite impressed with this, it was more than I was expecting, and certainly more than the electric blower on my own hearth at home, although much higher pressures have been reported in laboratory conditions.

The principle was later developed to a considerable degree in Canada, where the existence of plentiful water and deep falls enabled it to be used quite effectively as a hydraulic air compressor. J. P. Frizzell obtained a U.S. Patent in 1877, but major practical application followed the U.S. patent of Charles H. Taylor in 1895, who went on to found the Taylor Hydraulic Compressor Company of Montreal. Several installations were made, mostly utilising mine shafts (up to 100m deep), and air pressures of up to 9 atm could be generated to drive machinery. Tests indicated an efficiency of up to 82% (air power output/water power input). Only a few examples were exported from Canada, one to Germany and others to South America. The only one remaining is reported to be at the Ragged Chute mine near Cobalt, Ontario.

See website: <http://sections.asme.org/Milwaukee/history/51-taylorcompressor.html>

J. K. G. Boucher

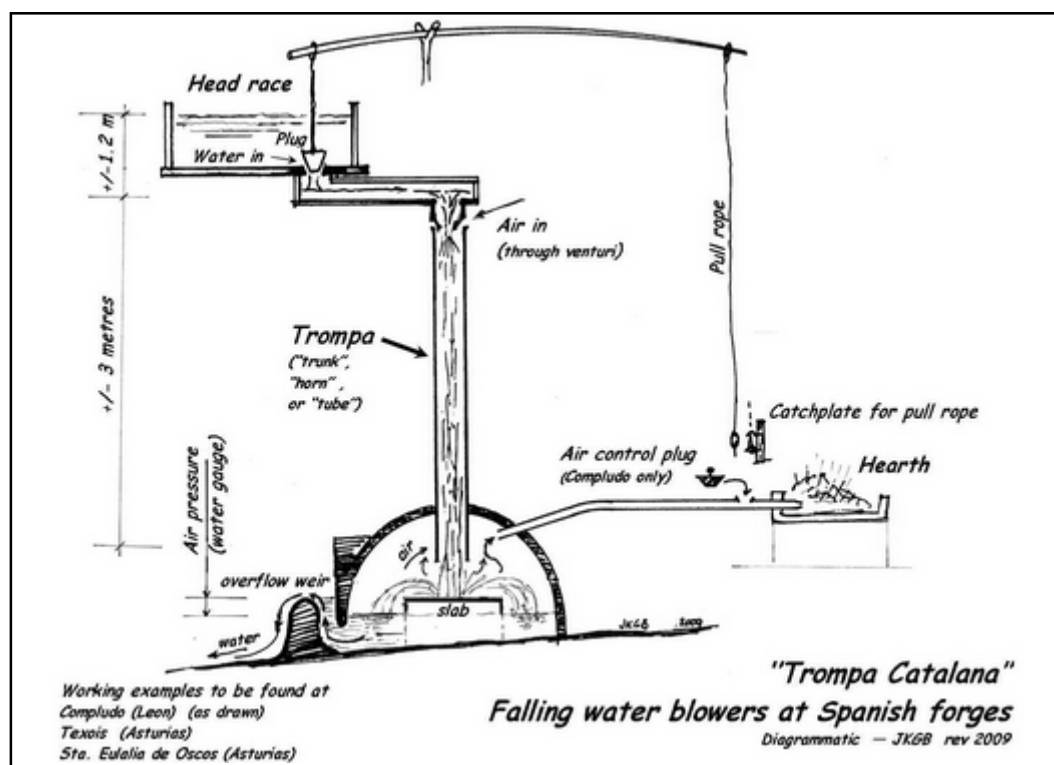

## Some Remnants of New York's Milling History

Last year was the 400th anniversary of the first Dutch people to set foot on shores of America at the place now called Manhattan. Some years later they built the town New Amsterdam; today known as New York.

This was also the beginning of the export of mill technology to America. The first mill was a horse mill erected by Frances Moelmacker (Millmaker?) which served the inhabitants of about 30 houses. In 1624 a large group of colonists settled on "Nooten Eylandt", later Governors Island, where Francoys Fezard built the first windmill, a saw mill. A second group of colonists that arrived in 1626, chose the southern point of Manhattan, where they built Fort New Amsterdam. They also built a windmill that can be seen in a painting by Vingboons. This painting shows a vista of New Amsterdam with the first windmill looking as if it were standing on the walls of the fort. However from maps made at that time it is obvious that the mill was located just outside the fort. A later map of 1639 shows three windmills, two saw mills and a corn mill.

Beside paintings, maps and pictures there are still other tangible testimonials of the mill history of New York to be found. In later years tide mills were very important in New

York. A number of these mills in Queens together with a variety of windmills exported flour to Great Britain and its colonies and made the town a centre of the flour trade. The coat of arms of New York City, showing two kegs or flour barrels and a set of four windmill sails, confirm the importance of this trade to the city. This coat of arms can be seen today on the facade of Paynter's Bank.

The earliest tide mill was built in 1657 by "burgher" Jorissen on Dutch Kill (kil is Dutch for creek). In 1881 this tide mill was pulled down to allow the construction of the Long Island Railroad. Burgers Sluice, the creek that regulated the water for the mill also disappeared. The Paynter family that operated the mill used the stones as a decoration for their house. Later on the stones became steps for the Long Island Savings Bank, and now they can be found in Queens Plaza North. Near this busy traffic point the millstones from the grist mill are embedded in a shabby sidewalk. The runner stone is 15 cm thick. People walk on them every single day thinking they are well-covers. The Greater Astoria Historical Society has now saved the stones for the future. They will be removed to a park in the neighbourhood due to their historical significance.

Huub van Est

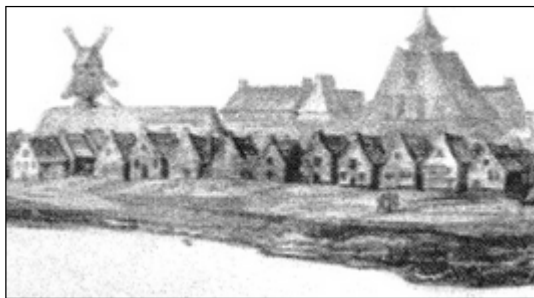

Fig. 1. Part of Vingboom's painting showing the first post mill.

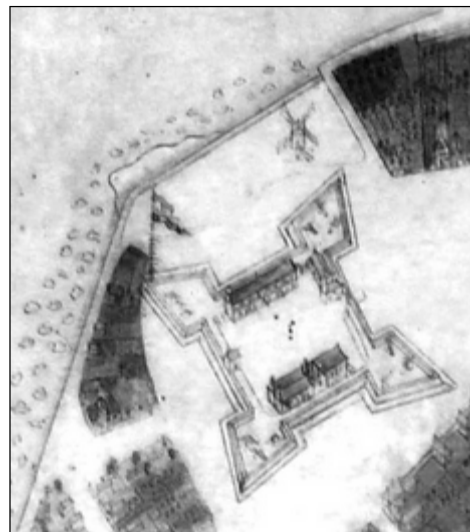

Fig. 2. Part of the map showing the post mill outside the fort.



Fig. 3. A millstone in the sidewalk at Queens Plaza North.

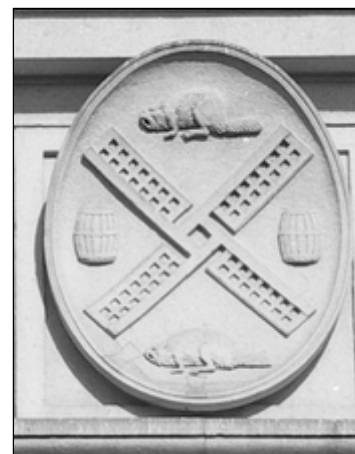

Fig. 4. New York coat of arms on the facade of Paynter's Bank.

Int Molinology 2010,80:43-44

**The Millstone Industry: A Summary of Research on Quarries and Producers in the United States, Europe and Elsewhere**

By Charles D. Hockensmith,

Published by McFarland & Co., 15th May 2009

Softback, 10 inch x 7 inch (251mm x 175mm)

269 pages, 80 illustrations inc, b&w photographs

ISBN 978-0-7864-3860-0

We are treated here to a compilation representing a huge amount of work. There is an occasional reference to the internet, but this is mostly the result of good, old-fashioned field work, consultation of the original documentation and with a host of people in a position to know some of the answers (though not all of them). In addition we are introduced to an enormous range of publications.

The extent of Charles Hockensmith's research efforts is reflected in the eight full pages of acknowledgments, while the succeeding introductory sections lay down the ground rules and explain the limitations of the book, and invite yet more work by other researchers. The current renaissance of millstone studies could, perhaps, have been projected back rather before 2002, perhaps to Gordon Tucker's modest but trail-blazing piece about his careful observations in the quarries on his overgrown Welsh hillside which was published in 1971, and which is duly acknowledged here in the bibliography.

Such a thorough and time-consuming enterprise deserves a better standard of production, however. This is a high price for a very tightly bound paper back. The photographs are all black & white on matt paper but are good and clear, though it is a pity that there is no scale on the millstone pictures. That there are so many partially-cut stones remaining on the sites to be photographed is a question answered in general terms: they may have had faults which only emerged as the work progressed, but many must have been abandoned when a quarry ceased operation. There are no maps or location plans, no doubt because it would be so difficult to know where to start. Intended as a source book for future researchers, it is therefore something of a catalogue, but there are welcome extracts, sometimes quoted at length, from manuscripts and other less accessible sources. The book is blessed with two essential research aids: there are some 34 pages of meticulously laid out bibliography (with some summary annotations where thought useful) and a detailed index running to another 15 pages.

Readers of *International Molinology* will probably be looking for the international links. In this respect, for example, the very first few pages provide a selection of intriguing glimpses into the life of the early settlers. This reviewer was inspired to spend an inordinate amount of time on the first eight pages which include, for example, a note from one John Winthrop in 1631. It turns out that he was newly arrived in 1630 and was promptly appointed governor of his colony in Massachusetts. A year later here he is asking his son, back in England, to send over some millstones "some two foot and some three foot over" with their iron fittings, and some mill bills (p.9). Perhaps we can find the relevant shipping details at this end. How many did young Winthrop think was meant by "some"?

There are other incidental hints at trading developments. In 1737 millstones manufactured primarily

for local use became "a profitable sideline, for they were ... shipped in schooners to the West Indies, where they were traded for slaves and Jamaica rum" (p.55). The sub-section on boulders used for millstones tells of the ingenuity of settlers in the first half of the 19th century. The Rev. Samuel Van Cleve was one such who was establishing the Brown township in Indiana (p.86) and, having built the Van Cleve mill, manufactured the millstones from a large grey boulder "which he split in halves and dressed them up to a true face, which did effective work while the mill stood". As late as the 20th century products from works in New York State produced stones only a few inches in diameter for hand-driven spice mills (p.39).

The American chapters provide a fuller story behind some of the expressions which are always encountered when reading about the milling industry in the U. S. Raccoon burrs from Raccoon Creek in Ohio were prized because they were some forty per cent cheaper than imported French burrstone, though they needed more frequent dressing (p.73). Esopus conglomerate stones came out of quarries in New York State from 1732 until early in the 20th century; Esopus was "the early name for Kingston, once the principal port of shipment" (p.37). Other details amongst the vast number recorded in these pages will no doubt strike a familiar note with members of TIMS.

Amongst the huge variety of American sources, Mt. Torn (Connecticut) would be a good place to hunt for a millstone quarry. The visit which Charlie Howell and I (together with Charlie's brother Bill and my wife) referred to by Charles Hockensmith (p.54) was indeed a fleeting one in the course of a four-day informally conducted tour. We did not have time to explore the hill, but we did find some tell-tale scraps of quartz conglomerate in the car park of the restaurant where we had a coffee break at the foot of the road which led up the slope.

By the middle of the 19th century stones made from French burr imports were usually asked for by the millers. At least one manufacturer - he claimed to be the only one - maintained a resident representative in France around 1828 (p.95) but no doubt other firms had their spies on the ground. American importers in 1870 were certainly canny enough to order their ready-built stones without the plaster backing, partly to save weight, but especially to expose the uniform quality and thickness of the burrs of which they were composed (Ward, 1986a in Hockensmith's bibliography). Problems of transport, however, meant that monoliths from France were unknown, and plaster of Paris came, according to one millstone builder, from "Nova Scotia and the Lake Erie region" (p.95).

The pages which focus on the American millstone industry are followed by a chapter on foreign imports. This provides a glimpse from the receiving end of the trade which is often referred to in European studies on the same subject, but the two ends do need to be joined up.

The section on millstone quarrying elsewhere in the world benefits enormously from work done in those locations which have hosted the two conferences on the subject of millstones that have been held so far (both of them in France) and one that was envisaged in Germany in 2008 but has not taken place. The overall purpose of this chapter is to "discuss the literature" on millstone and quern sources outside the U.S.A. The relative abundance of published material on countries in Europe, and especially

the British Isles, is usefully and thoughtfully encapsulated here, but it is also good to see references to modest original contributions from smaller countries such as Slovenia. The major entries in this section have a number of striking photographic illustrations.

There are short chapters on artificial millstones and tools used in the millstone business, and the final few pages are devoted to a transcription from a colourful conversation between two old stagers who knew something of the working conditions in the millstone yards at first hand.

In short, we are provided here with a wealth of material, both original and collated from a vast range of published

and unpublished sources. But we are also deliberately sent on our way to pursue the work which is now arousing renewed interest.

Owen Ward

Price £60.50 Available from Eurospan Group at:  
[www.eurospanbookstore.com](http://www.eurospanbookstore.com)

Price \$75.00 Available from the publisher at:  
[www.mcfarlandpub.com](http://www.mcfarlandpub.com)

### Windmills of Yorkshire

By Roy Gregory & Laurence Turner

Published by Stenlake Publishing Ltd., December 2009

Softback, 8 inches x 11 inches (20cm x 28cm)

112 pages, 150+ b & w photos

ISBN 9781840334753



To many people, particularly in West Yorkshire and further afield, windmills in Yorkshire may come as a bit of a surprise. One thinks immediately of the water-driven textile mills, water-powered forges and cutlery polishing shops around Sheffield and the many water-powered corn mills once found throughout this large county.

Roy Gregory and Laurence Turner have both been engrossed in the study of traditional mills for many years. Roy has already published authoritative books on the Windmills of East Yorkshire and *The Industrial Windmill in*

*Britain*, the latter covering wind-powered industries other than grain milling. Laurence, based in the Leeds area, has uncovered much new and previously unpublished material of the former windmills of West Yorkshire.

The authors have produced the first authoritative work on windmills in the whole county and published many historic prints for the first time. They have cleverly woven a fascinating story of the development of windmills, their differing types, technology and uses. This illustrated book provides history and technical information on more than 180 windmill sites accompanied by over 150 photographs, maps and drawings. The remains of many of these can still be seen around the hills, dales and small villages of Yorkshire. Map references are provided for the enthusiast to create a personalised tour of these fascinating molinological sites.

At the latter part of the 18th Century leading British and Dutch engineers and millwrights, such as John Smeaton, came together in Yorkshire, particularly in Leeds and Kingston upon Hull, to develop a new breed of advanced tower windmills. These work horses of industry, before the development of safe and reliable steam engines, were vital to the growth of industry in places like lowland Hull and the East Ridings bereft of good water-powered sites. Tall brick towers, automatic sail furling and cast iron gearing together with other novel innovations led to some of these mills becoming the most advanced in the world.

Clear photographs and graphic text portray a vanished past when these machines played a vital part in the well being of many communities. The people who toiled with and often against the elements in many industries and the slow decline and demise of these evocative structures are well illustrated. A full alphabetical index of the locations is provided starting at Aberford, Hicklam Mill, passing through Beverley Back Mill, Beverley Fishwick's Mill, Beverley Hither Mill, including six different mill sites around Leeds and terminating in York at Holgate Mill.

I can wholeheartedly recommend this reasonably priced, good quality study to anyone interested in Yorkshire's heritage, local or family history and the study of molinology in general. This is the first volume of what is anticipated as a series covering the whole of England. If this is a foretaste I look forward to further volumes.

Jon A. Sass

Price £13.95  
Available from the publisher at: [www.stenlake.co.uk](http://www.stenlake.co.uk)

## 13th TIMS Symposium

More than 40 years have past since TIMS last visited Denmark for the Second Symposium in 1969, and we are happy to invite you all to come once more to the land of Poul la Cour and Anders Jespersen.

The 13th Symposium will take place in Aalborg, Denmark, from the evening of Saturday the 3rd September to Sunday the 11th September, 2011, during which there will be a varied program of lectures and visits to mills. Aalborg is easy to reach whether you arrive by train, bus or plane, and the conference center is situated close the old town center.

In the next issue of IM you will receive a "call for papers", but we can already reveal that we particularly would appreciate contributions on the subject "the correct preservation of mills". One day will be reserved for presentations from invited guests who will lecture on the subject "Foreign Influences on Danish millwrighting". There will also be an extensive partner program.

We offer pre-tour to the paradise of mills, Bornholm and Skåne (in southern Sweden), with departure from

Copenhagen on 30th August, and post-tour to Southern Denmark. The post-tour will finish in Copenhagen 14th September, 2011.

Unfortunately, price levels in Denmark are rather high, but we are trying very hard to get the price for the Symposium to below 1200€ with a rebate for "early birds". We are also trying to offer a number of places at a reduced price for students and members from soft currency countries in exchange for the contribution of a paper to the Symposium.

We look forward to see you in Denmark!

On behalf of the planning committee



Lise Andersen  
*chairman*

## William Howell (1931 – 2009)†



I was saddened to learn of the death of Bill Howell and I know our members will be sorry to hear he had died on 1st November 2009 after a recent illness. He was the youngest of seven children and all five sons were associated with either milling, farming or a transport business.

I was first introduced to the Howell milling family by the late Rex Wailes and Jack Crabtree in the mid 1950s, when they operated a small country mill on the River Sow at Worston, Staffordshire. It was a good, hard working water mill which always seemed plagued by bureaucracy or natural disasters. The problems with the River Authority in the 1960s caused headaches at Worston Mill and many other mills trying to make a living the old fashioned way. The beloved cattle which Bill had worked so hard to raise were lost because foot and mouth disease in the area had dictated they must be destroyed even though they were not

themselves infected. The Government then nationalized the transport system in Britain causing further headaches with their small family business. It was about this time that Bill's brother Charlie Howell, who died in 1993, moved to the United States and became the miller at Tarrytown, New York and where Bill was a frequent visitor.

Bill was a very gentle man with a great smile and memorable laugh. He was also very hard of hearing but that disability never put him off from making good his opinion or views known, especially when talking with people who eagerly sought his knowledge of either milling or farm management. I well remember him being asked by several 'Working farm Museum' students and experts about the forthcoming birth of a calf. They had told him the calf was due momentarily but Bill disagreed and said she needs two more weeks! After many sleepless nights they had to admit Bill was right and the calf was born exactly on time to his prediction.

I always enjoyed being with Bill and Charlie, particularly when talking with American mill enthusiasts, as we could relate our own stories from the past and often in a Staffordshire dialect never totally understood by any of them. Bill's stories were equal to Charlie and all were true and accountable. They surely must have inherited this gift from their father William Senior, who was a master in the art. He was an older generation of real true millers and also a gentleman. I will never forget William Senior sitting in the middle seat at the rear of a bus on a SPAB summer mill tour of Derbyshire, when the enthusiastic driver suddenly announced we were now passing the oldest Pub in England. William instantly and strongly protested his disapproval by loudly asking 'Why?'

Sadly, it is the end of a generation of the Howell family and their presence will be missed by their many mill friends in Britain, United States of America and around the World. They will not be forgotten.

Derek Ogden.  
January 2010.

*International Molinology*, Journal of The International Molinological Society, has been published twice a year since December 1994. The earlier issues (No. 1 to No. 48) were published in a simpler format, most recently under the title 'TIMS Newsletter' (ISSN 1019-9861). The editor welcomes articles on all aspects of molinology, as well as related news items, reports, announcements, questions, comments, photos and book reviews.

#### **Guidelines for Authors**

**Contributions:** Material should be sent to the Editor, Tony Bonson, 14 Falmouth Road, Congleton, CW12 3BH, United Kingdom  
email: [tonybonson@googlemail.com](mailto:tonybonson@googlemail.com)

Contributions are only published in English, the official language of TIMS. If English is not the first language of the author, it is recommended that an English-speaking colleague or fellow member of TIMS be asked to go over the text before it is submitted to the editor. The editor will always assist non-English contributors to improve their contribution and will make every attempt to find suitable translation capabilities.

Material should be printed on one side of A4 (210 x 297 mm) or in the American Letter-size (8.5 x 11 inch). It would be greatly appreciated if authors would send contributions not only typed, but also on a CD or by email. Illustrations, either photographs or drawings, should be included wherever possible. Do not embed any illustrations in a word processing file, especially in MSword files.

**Arrangement: Title page:** The first page should contain the title, sub-title (if any), the author's full name together with their full postal and email addresses.

**Tables & Illustrations:** They are both numbered in Arabic numerals. Tables require a heading and illustrations a caption.

**Footnotes:** The International Molinology house style does not include footnotes. References should be used and placed at the end of the article.

**References:** In the text identify references by Arabic numerals in square brackets or in superscript. The information supplied in a reference should be as follows:- For an article, provide the author(s) name(s), article title, publication title, volume (& part) number, publisher's name, publication date, and page numbers in the publication. For a book, provide the author(s) name(s), book title, publisher's name, and publication date (optionally, also the page numbers).

**Photographs:** Ideally these will be supplied as a digital image either from a digital camera or from a scanner. Digital photographs should use the "best" or "fine" quality settings and scans should have a resolution such that the reproduced version is at least 300 dpi. Digital images should be provided in an uncompressed file such as a .bmp file or .tif file, alternatively a compressed .jpg file can be used but will result in some loss of definition (Note. jpeg files of below 50Kbytes will have poor definition)

**Book Reviews:** Provide the complete bibliographical data, i.e. title, sub-title (if any), translation of the title in English (if a non-English publication), author(s), format (size), number of pages, number of illustrations, and ISBN. Also include the postal and/or email address for orders and the selling price.

**Conditions:** The editor prefers to publish original articles based on original research. Material that has been previously published or currently under consideration by any other publisher may be accepted, but should be accompanied by permission from the copyright holder. All contributing authors should ensure that all their material has permission from any copyright holders for its use.

**Deadlines:** Material for publication in *International Molinology* should reach the editor no later than 2 months prior to the publication date, i.e. 1st April and 1st October.

---

## **The International Molinological Society**

---

The International Molinological Society (TIMS) has been active since 1965 and is the only organization dedicated to mills on a worldwide scale. It brings together more than five hundred members, mostly from Europe and the USA. TIMS is a non-profit-making organization with cultural and scientific aims. It was founded in 1973 after earlier international meetings (Symposia) in 1965 and 1969. The original initiative for these meetings was taken by the Portuguese molinologist Dr. João Miguel dos Santos Simões, who was also the first to use and define the term 'molinology' as "*the description and the study of mills or other mechanical devices, using the kinetic energy of moving water or wind as a motive power for driving grinding, pumping, sawing, pressing and fulling machines. More particularly, molinology aims at the knowledge of those traditional engines which have been condemned to obsolescence by modern technical and economic trends, thus being a chapter in the History of Technology and part of the History of Civilization*" (May 15, 1962, see Trans. 1st Symposium Molinology, Cascais 1965, p. 41). Today we consider muscle-powered mills to be part of molinology as well.

The TIMS symbol consists of a windmill, derived from a half penny token issued at Southwark (UK) in 1667, placed inside a reproduction of the rims, starts and paddles of the waterwheel at Woodbridge Tide Mill in Suffolk (UK).

#### **TIMS Executive Council Members**

**President:** Willem D. van Bergen, Eichendorffstrasse 45, D - 71665, Vaihingen/Enz, Germany, Tel.: +49.7042.288180, Mobile: +49 172 828 1566, Fax: +49 7042 958484, email: [wdvb@gmx.de](mailto:wdvb@gmx.de)

**Secretary:** L. van der Drift, Groothertoginnelaan 174b, 2517 EV Den Haag, The Netherlands, Tel. +31-70-3460885, email: [tims.secretary@telfort.nl](mailto:tims.secretary@telfort.nl)

**Treasurer:** Johan De Punt, Kerkveldstraat 55, B - 9420 Mere, Belgium, Tel. and Fax: +32.53.840299, email: [depunt.mill@gmail.com](mailto:depunt.mill@gmail.com)

**Scandinavia:** Lise Andersen, Hadsund Egnas Museum, Rosendalsallé 8, DK-9560 Hadsund, Tel. +45 9931 7463, fax +45 9652 0515, email: [ila-kultur@aalborg.dk](mailto:ila-kultur@aalborg.dk) (all Scandinavian countries)

**France:** B. Deffontaines, Moulin des Fontaines, 10, rue du Paradis, F-37510 Savonnières, email: [Benoit.deffontaines@wanadoo.fr](mailto:Benoit.deffontaines@wanadoo.fr)

**Germany:** G. Bost, Bulgenbachweg 24, D-13465 Berlin, Tel. +49-30-4061519, Fax +49-30-40100818, email: [tims@windmill.de](mailto:tims@windmill.de)

**Netherlands:** T. Meesters, Zandoogjes 6, 4814 SB Breda, Tel. +31-76-5207869, Fax +31-76-5207869, email: [ton.meesters@mazars.nl](mailto:ton.meesters@mazars.nl)

**Switzerland:** Heinz Schuler, Route de Sous-Tour 30, CH - 1562 Corcelles-près-Payerne, Tel. +41.26.6601000, email: [archdoku@bluewin.ch](mailto:archdoku@bluewin.ch)

**UK:** Mildred Cookson, 13 Littlestead Close, Reading, Berks, RG4 6UA, Tel.: +44.1189.478284, email: [mildred@stonenut.demon.co.uk](mailto:mildred@stonenut.demon.co.uk)

**USA:** Lisa Steen Riggs, P.O.245, Elk Horn, IA 51531, Tel. +1-800-451-7960, Fax +1-712-764-7475, email: [lisa@danishwindmill.com](mailto:lisa@danishwindmill.com)

**Corresponding Member for Portugal:** Jorge Miranda - EtnoIdeia, Rua da Mãe de Água, 10 - Rch A Belas Clube de Campo, P - 2605-199 BELAS, Portugal, Tel/Fax: + 351 21 962 5004, email: [tims@netcabo.pt](mailto:tims@netcabo.pt)

**Corresponding Member for Greece:** Stephanos Nomikos, 154 Alexandras Avenue, 114 71 Athens, Greece. Tel: 30 210 6464974; email [snomi@tee.gr](mailto:snomi@tee.gr)

**Editor:** Tony Bonson, 14 Falmouth Road, Congleton, CW12 3BH, United Kingdom, Tel.: +44.1260.276351, email: [tonybonson@googlemail.com](mailto:tonybonson@googlemail.com)

#### **TIMS Membership Secretary**

Any change of address, telephone or FAX should be sent to Dave Gregory, The Windmill, Norwell, Newark, Notts NG23 6JN, Great Britain, email: [davejgrego@gmail.com](mailto:davejgrego@gmail.com). New members are requested to apply to the Council member concerned or to the TIMS Treasurer.

#### **TIMS Homepage on the Internet**

<http://www.timsmills.info>



---

## Publications of The International Molinological Society

---

Unless stated otherwise, all publications are in English.

### Bibliotheca Molinologica

The series Bibliotheca Molinologica (ISSN 1021-5581), published at irregular intervals, consists of the following titles:

- Volume 6 Jarvis, P.S.: Stability in Windmills and the Sunk Post Mill. 40 pp. Second, revised edition (1999). ISBN 92-9134-013-8  
Volume 7 Limona-Trebela, E.: Windmills of the Aegean Sea. 27 pp. (1983). ISBN 92-9134-014-6  
Volume 10 Harverson, Michael: Persian Windmills. 65pp. (1991). ISBN 90-73283-03-5  
Volume 11 Ward, Owen: French Millstones. Notes on the Millstone Industry at la Ferté-sous-Jouarre. 75 pp. (1993). ISBN 92-9134-018-9  
Volume 12 Moog, Berthold: The Horizontal Watermill. History and Technique of the First Prime Mover. 96 pp. (1994). ISBN 92-9134-017-0  
Volume 13 Woons, Frans: Index Papers TIMS. Index of papers and articles in TIMS Publications. 32 pp. (1998). ISSN 1021-5581 **Out of print, can be consulted on the TIMS website**  
Volume 14 Blom, Louis H.: The Windmills of the Greek Islands. 208 pp. (1999). ISBN 92-9134-019-6  
Volume 15 Lambrecht, Kalman: The Hungarian Windmill. 60 pp. (1999). ISBN 92-9134-020-3  
Volume 16 Coutant, Yves: Windmill Technology in Flanders in the 14th and 15th centuries. 92pp. (2001). ISBN 92-9134-021-9  
Volume 17 Ward, Owen; Watkins, George: The Mills of Bédidor. 76pp (2002). ISBN 92-9134-022-7  
Volume 18 Baker, T.Lindsay: A Guide to United States Patents for Windmills and Wind Engines 1793-1950. 120pp (2004). ISBN 92-9134-024-3  
Volume 19 Gräf, Daniela. Boat Mills in Europe from Early Medieval to Modern Times. 367pp (2006). ISBN 3-910008-73-9

Volumes 1, 2, 3, 4, 5, 8, 9 and 13 out of print.

### Transactions of Symposia

The Transactions of Symposia contain all papers on molinological subjects presented during the Symposia, sometimes also discussions and other contributions. The following volumes have been published:

- Transactions of the 1st Symposium, Cascais/Lisboa, Portugal, 1965. 280 pp. (1977). ISBN 92-9134-001-4  
Transactions of the 2nd Symposium, Holte, Denmark, 1969, 590 pp. (1971). ISBN 92-9134-002-2  
Transactions of the 3rd Symposium, Oosterbeek, The Netherlands, 1973. 192 pp. (1974). ISBN 92-9134-003-0  
Transactions of the 4th Symposium, Matlock, Great Britain, 1977. 420 pp. (1978). ISBN 92-9134-004-9  
Transactions of the 5th Symposium, Claye-Souilly, France, 1982. Bilingual (French and English), 552 pp. (1984). ISBN 2-904939-00-8  
Transactions of the 6th Symposium, Gent, Belgium, 1985. 365 pp. (1986). ISBN 92-9134-005-7 **Out of print**  
Transactions of the 7th Symposium, Sankelmark, Germany, 1989. 488 pp. (1994). ISBN 92-9134-006-5  
Transactions of the 8th Symposium, Aberystwyth, Wales, Great Britain, 1993. 204 pp. (1995). ISBN 92-9134-007-3  
Transactions of the 9th Symposium, Budapest, Hungary, 1997. 292 pp. (2004). ISBN 92-9134-023-5  
Transactions of the 10th Symposium, Stratford, Virginia, USA, 2000. 340 pp. (2002). ISBN 0-9720597-0-9  
Transactions of the 11th Symposium, Amadora & Boticas, Portugal, 2004, 278 pp. (2007) to be ordered exclusively from our Representative in Portugal, Mr Jorge Miranda, by sending an email to [tims@netcabo.pt](mailto:tims@netcabo.pt)  
Transactions of the 12th Symposium, Putten, The Netherlands, 2007, 520 pp. (2008). ISBN 978-90-9023293-5 to be ordered exclusively from TIMS-NL/VL, by sending an email to the Secretary, Mr Wiard Beek, email : [wiardbeek@gmail.com](mailto:wiardbeek@gmail.com)

Unless stated otherwise, publications in the series Bibliotheca Molinologica and TIMS Transactions can be ordered from the The Mills Archive at <http://shop.millsarchivetrust.org> (choose the category 'books', then 'TIMS publications'). If you are America-based, it might be easier to try the Danish Windmill online store which also keeps many of our titles in stock. Web address : [www.danishwindmill.com](http://www.danishwindmill.com) (choose 'mills & more').

**TIMS Newsletters:** From 1974 to 1995 the Newsletter was the bulletin of TIMS. The later issues especially contain substantial articles. All Newsletters issued (No. 1 to 48), about 450 pages of A4 in all. **Out of print.** Photocopies of individual articles can be ordered from the TIMS Secretary. Three articles, too long for inclusion in early Newsletters, were printed as addenda: to NL 11 (1978), Marringa-Stapff, A.J.: Mills of Surinam. 10 pp.; NL 21 (1982) Takats, S.: The Hungarian Mill. 7 pp.; NL 41 (1990) Buckland, J.S.P.: Essington Post Mill. 7 pp. They are still available in original or photocopied form and can be ordered separately.

**International Molinology:** This is the continuation of the Newsletter from 1995 (No. 49) onwards. Each recent issue contains 40-48 pages and can be ordered separately. The following numbers have been issued since December 2000 (with brief description of main contents):

- No. 61 E.G.Marin – A Forgotten Molinologist/ The Tanbark Mills of Chios/ Danish Experiments with Reefing Windmill Sails (December 2000)  
No. 62 Tenth Symposium / A Czech Windmill?/ Greek Windmills in old pictures/ Watermills of the Dodecanese / Tidemills in Tasmania (July 2001)  
No. 63 Small Coastal Windmills / Panster Mills / Windmills in Cyprus, Turkey and Tasmania / A Sicilian watermill / Relation between Millstone and Sail or Waterwheel Speeds / The Institute of Hellenic Mills (December 2001)  
No. 64 Windmill Sails / Early waterpowered sawmill in Jordan / Syrian Watermills/ French Millstone Industry/ German Tide Mills (July 2002)  
No. 65 Tribute to Claude Rivals / Boat Mill on the Tam/Rice Milling in Japan / Australian Horizontal Watermill (December 2002)  
No. 66 Azores mills / Mill Preservation in Greece / Suriname tide mills / South African cormills (July 2003)  
No. 67 Mills of the Baltic States / Horizontal windmills: an overview / Milling in the UK since the 1880s (December 2003)  
No. 68 Tributes to Anders Jespersen / Maltese windmills / Watermills in Shetland and W. Australia / Typological Questions in Molinology (July 2004)  
No. 69 Greek Island watermills / Waterpowered striking of coinage / Windmills of Crete, Minorca, Formentera and Iceland (December 2004)  
No. 70 11th Symposium/ Eucharistic Mills/Horizontal Windmills of Andros/Marble sawing mill/Dutch Tide Mills (July 2005)  
No. 71 Temporary watermills in Portugal/Austrian mangle/Hebridean watermill/French multi-sailed windmills (December 2005)  
No. 72 French millstone bibliography/18th-cent. Breton mills/ Swiss saw mills/ A new perspective on [Dutch]mills (July 2006)  
No. 73 Mills of SW France/ Greek watermills/ Breton millstone trade/Windshaft displacement/Sail weather (December 2006)  
No. 74 Danish windmill sails/ The medieval Paris boat mills/ A marble-sawing mill in ancient Turkey/ Mills of the Greek Peloponnese/ A UK millstone studies bibliography/ Irish archaeological research on medieval watermills (July 2007)  
No. 75 Twelfth Symposium/'Hoarded' Mills/ Horizontal Mills of S. Khorasan/Kalgachika Village Mill (December 2007)  
No. 76 Early American Flour Manufacture & Export/ Mills in Slovenia/ Windmill Washing Machines/ A New Zealand Sawmill. (July 2008)  
No. 77 Midlands-type Postmills/ Millwrighting Bibliography, Part 1/ Boat Mills in New Zealand. (December 2008)  
No. 78 Oblique scoop wheels/Basque Country tide mills/Wind pumps on Netherlands country estates/German windmills with over 5 sails. (June 2009)  
No. 79 Czech Republic Mill Tour/German Composite Mills in the Ukraine/Millwrighting Bibliography pt 2/Marble Mill of Neidlingen. (December 2009)

**See the International Molinology page on the TIMS website, where a full list of contents of all issues is given. Please note that volumes 49, 53, 57, 58, 63 and 66 are out of print.**

**For further information, including orders for back issues of International Molinology and photocopies of single articles, please contact the TIMS Secretary: Leo van der Drift, Groothertoginnelaan 174-b, 2517 EV Den Haag, The Netherlands, email: [tims.secretary@telfort.nl](mailto:tims.secretary@telfort.nl).**

# International Molinology



ISSN 1024-4522

Editor: Tony Bonson  
Lay-out by Ian Scotter  
© The International Molinological Society, 2009

## Contents No. 80, June 2010

- 1 Editorial
- 2 First International Molinological Conference in Ukraine
- Original Papers**
- 4 Current Wheel Dredges in New Zealand
- 11 Alkmaar as the Nursery of Holland's Industrial Windmills around 1600
- 26 Sugar Mills (Tawahin es-Sukkar) in the Jordan Valley
- Communications**
- 35 The Donixmühle in Oberseifersdorf, Germany
- 38 Leonardo's Mill for Milan
- 39 Jerusalem's Montefiore Mill to be Restored
- 40 Hart Park Waterwheel, Bakersfield, California
- 41 Trompas Catalanas
- 42 Some Remnants of New York's Milling History
- Mill Literature**
- 43 The Millstone Industry: A Summary of Research on Quarries and Producers in the United States, Europe and Elsewhere
- 45 Windmills of Yorkshire
- 46 13th Symposium; Obituary: William Howell

Front cover: "De Gekroonde Poelenburg" at the Zaanse Schans. Photograph by H. Kaptein.  
Back cover: Windmills at Zaanse Schans. Photograph by H. Kaptein.



Industrial windmills at Zaanse Schans open air museum. Photograph by H. Kaptein.



Drainage mills near Schermerhorn. Photograph by H. Kaptein.

# International Molinology



ISSN 1024-4522

